



THE UNIVERSITY OF
TENNESSEE
KNOXVILLE

Office of Information Technology
Communications Group

Telecommunications Design and Installation Standards

Introduction

Telecommunications: The transmission of words, sounds, images, or data in the form of electronic or electromagnetic signals or impulses.

The intent of this document is to provide recommended practices for the design and installation of UTK's Telecommunications infrastructure that will support a wide variety of existing and future services using industry accepted design and installation methods. UTK attempts to define standards that will enable the design and implementation of structured cabling systems for commercial buildings and between buildings in a campus environment. UTK recognizes, and adopts for itself, the telecommunications industry standards, codes, and practices as defined in the agencies listed in Section 1. UTK intends to build an ITS system that is vendor neutral and standards based.

This document is intended to answer FAQ of UTK OIT's infrastructure practices and not to be a substitute for knowledge of industry accepted practices, standards, and codes. This document is **NOT** intended to be used in lieu of a construction specification document, but to be an addition to the specifications.

Communications technologies are complex. They shall be designed and installed by experienced professionals. UTK OIT strongly recommends a Registered Communications Distribution Designer (RCDD) be used as a consultant for the design of the telecommunications. In many cases, the need will arise to consult with other engineers from other trades or areas of expertise. UTK OIT supports or aids in the delivery of telecommunications for a wide variety of services and spaces, on and off campus such as:

- Offices
- Classrooms
- Computer Labs
- Data Centers
- Residential Housing
- Outside Campus Backbone Plant
- Sports Arenas and Stadiums
- Physical Activity Centers
- Health Care Facilities
- Museums
- Recording Studios
- Research Laboratories
- Building Automation Systems
- Food Services, Restaurants, Cafeterias, and Vending
- Warehouses
- Innovation Labs
- TV and Radio Studios
- Video Security
- Access Security
- 911 Police Dispatch
- Forensics Labs
- Fire Alarm

UTK Facilities Services/Planning and OIT intend to work in a “team” atmosphere with all parties. Our goal is to build a quality Telecommunications Infrastructure by partnering with the design team, consultants, and contractors. It is encouraged for all parties to ask questions and/or resolve conflicts in a professional, reasonable, and timely matter.

UTK OIT will have final review, approval, and be the acceptance authority for all telecommunications infrastructure, designs, installations, materials, and methods, in all phases of the design and installation process. This standard will change to meet industry recognized standards. The designer, consultants, and installers are responsible for inquiring about updates. This document shall be made available to any vendor (General, Electrical, HVAC, Security, Telecommunications and Fire Alarm Contractors) considering bidding on a project.

Table of Contents

1. Design and Installation Codes & Standards.....	6
2. Design / Engineering Standards	7
2.1 UTK OIT Requirements	
2.2 Standards Variance	
2.3 Equal or Equivalent Submittals	
2.4 Master Format 2004/2011	
2.5 T-Drawings	
2.6 Bid Documents	
2.7 Telecommunications Spaces (27 11 00)	
2.7a Entrance Facility (EF) (27 11 00)	
2.7b Equipment Room (ER) / Telecommunications Room (TR) (27 11 00)	
2.7b.1 ER/TR Space Allocation (27 11 00)	
2.7b.2 ER/TR Layout (27 11 00)	
2.7b.3 ER/TR HVAC (23 82 19)	
2.7b.4 ER/TR Power Requirements	
2.7b.5 ER/TR Lighting	
2.7c Telecommunications Enclosures (TE) (27 11 16)	
2.8 Telecommunications Pathways (27 10 00)	
2.8a Conduits and Sleeves (27 05 28.33)	
2.8b Cable trays (27 05 28.36)	
2.8c J-Hooks (27 05 28.29)	
2.9 Outside Plant (OSP) (27 05 43)	
2.10 Horizontal cabling (27 15 00)	
2.10a 100 ohm UTP CAT5e/CAT6 (27 15 00.19)	
2.10b Coaxial Cable (27 15 33)	
2.10c Work Area Outlets (WAO) (27 15 43)	
2.10d Office Space	
2.10e Modular Furniture	
2.10f Classroom / Labs	
2.10g Residence Life (Housing)	
2.10h Conference Rooms	
2.10i Break Rooms, Lobby/Others	
3. Construction / Installation Standards	18
3.1 Certifications and Professionalism	
3.2 UTP/Coax/Fiber Optic Installation	
3.2a Inspections and Walk Through	
3.3 Commissioning and Documentation (27 08 00)	
3.3a Warranties (27 08 00)	
3.3b Test Results (27 08 00)	
3.3c Administration/Labeling (27 05 53)	
3.4 Firestopping	
4. Other Telecommunications	20

- 4.1 Multi Media
- 4.2 Wireless LAN (27 21 33)
- 4.3 Security Cameras
- 4.4 Code Blue Emergency Phones (27 32 56)
- 4.5 Elevator Phones (27 32 23)
- 4.6 Building Access / CBORD
- 4.7 Building Control / BAS
- 4.8 Fire Alarm Communications

Appendix22

- A. Material and Part List
- B. TR Layout
- C. Standards Variance Form
- D. Registration for Installation Warranty
- E. Grounding / Bonding
- E-1. Telecommunications Grounding Bus Bar (TGB)
- F. Pull Box (PB) / Hand Hole (HH) figure
- F-1. Pull Box Configurations
- G. Legends
- H. Smart Conduit Body (Telecommunications LB)
- I. Telecommunications Enclosure
- J. Fire Stop
- K. Rack Layout
- L. Schedule
- M. Labels
- N. Riser
- O. Outside Plant OSP

Abbreviations.....43

Glossary.....48

1. Design and Installation Codes and Standards

The purpose of codes, in general, is for the practical safeguarding of persons and property from hazards, and to ensure the quality of construction.

Standards are requirements affecting the performance of a given system. As defined in the TIA Engineering Manual, a standard is “A document that establishes engineering and technical requirements for the processes, procedures, practices, and methods that have been adopted by consensus. Standards may also be established for selection, application, and design criteria for material.”

It is **expected** that the Telecommunications Infrastructure to be designed and installed to the following codes, standards, and practices (**current editions**):

BICSI ITSIMM current edition (Information Technology Systems Installation Methods Manual)

BICSI TDMM (Current Edition) (Telecommunications Distribution Methods Manual)

ANSI/NECA/BICSI – 568-C.0, Standard for Installing Commercial Building Telecommunications Cabling

ANSI/TIA/EIA 569-(Current Edition), Commercial Building Standards for Telecommunications Pathway and Spaces

ANSI/TIA/EIA 568-(Current Edition), Generic Telecommunications Cabling for Customer Premises Standard Series

568-(Current Edition).1 Commercial Building Cabling

568-(Current Edition).2 Copper Cabling Components

568-(Current Edition).3 Fiber Cabling Components

568-(Current Edition).4 Coax Cabling Components

ANSI/TIA/EIA 606-(Current Edition), Administration Standard for Commercial Telecommunications Infrastructure

ANSI J-STD-607-(Current Edition), Commercial Building Grounding (Earthing) and Bonding Requirements for Telecommunications

ANSI/TIA/EIA 758-(Current Edition), Customer Owned Outside Plant Telecommunications Cabling Standard

ANSI/TIA/EIA-526, 7 & 14(Current Edition), Telecommunications Measurements of Optical Fiber Single and Multi Mode Power Loss

ANSI/EIA 310-(Current Edition), Cabinets, Racks, Panels and associated Equipment

ANSI/SCTE 15 2001(Current Edition), Specifications for Trunk, Feeder and Distribution Coaxial

ANSI/SCTE 74 (Current Edition), Specification for braided 75 ohm Flexible Coaxial Cable

ANSI/TIA/EIA 862(Current Edition), Building Automation Systems Cabling Standard For Commercial Buildings

ANSI/INFOCOMM 1M-2009, 2M-2010, 3M 2011, Audiovisual Systems Design

FCC Part 68, Connection of Terminal Equipment to the Telephone Network

FCC Part 76, Cable Television Service

ADA of 1992 and Telecommunications Act of 1996, Physically Impaired and Accessibility

IEEE 802 – (Current Edition), Standard for Local and Metropolitan Area Networks: Overview and Architecture.

IEEE 802.3.xx (Current Edition), Physical and Data Link layer standards for LAN's, Includes Ethernet, Fast Ethernet, Gigabit Ethernet and 10 Gigabit Ethernet

IEEE 802.1.xx (Current Edition) Wireless LANs

IEEE 802.16(Current Edition), Broadband Wireless Metropolitan Area Networks

IEEE C2-(Current Edition), NESC (National Electrical Safety Code)

NFPA-70 NEC-(Current Edition) (National Electrical Code)

NFPA-76(Current Edition), Recommended Practice for Fire Protection of Telecommunications Facilities

NFPA 101(Current Edition), Life Safety Code

All applicable State, Municipal & Campus codes, standards and Statutes

Be aware that these codes and standards are updated regularly. However, these codes and standards do not necessarily coincide with each others' revision dates. It is the responsibility of the designer, contractor, and installer to be aware of any changes and be governed by these new issues when required.

2. Design / Engineering Standards

2.1 UTK OIT Requirements

The design team shall consult with UTK OIT for specific needs and practices. These include implementation of Voice over Internet Protocol (VoIP), LAN Security Cameras, LAN equipment, Wireless LAN, Classroom setup and equipment, the use of CAT5E or CAT6, Fiber Optic type and count, CATV etc.

2.2 Standards Variance

If the need ever arises that a standard cannot be met during the design or installation, then a "Standards Variance Form" must be filled out and sent to the UTK Project Coordinator who will deliver to UTK OIT for approval or denial. A copy of this form can be found in Appendix C.

2.3 Equal or Equivalent Submittals

Submittals play a critical role in construction. During construction, submittals confirm the contractor has met the designer's and owner's intent. Post construction, they serve as part of the as-built resource. Submittals' shall be submitted in such a way as there is a clear indication of what is being submitted, i.e. by circling (not highlighting), manufacturers part numbers (not distributors' numbers), in a legible manner. UTK has standardized on a number of performance and warranties criteria relating to the campus network infrastructure. UTK OIT will provide to the design team a list of products to be used as a benchmark for equal or equivalent (terminology such as "similar" is not to be used). Submittals for any possible substitutions must be submitted to UTK OIT before the bid process and be consistent with the language of the bid document. The submittals must include full specifications and warranties and be verified with a recognized testing laboratory such as UL or ETL.

2.4 Master Format (Current Edition)

The Construction Specification shall follow the Master Format 2004/2011 numbers and titles. Most of the specifications for Telecommunications will be found in Section 27. There are instances where Telecommunications related work will fall into other sections. An example is to keep conduit and pull boxes requirements for Telecommunications in Section 27 and reference them in Section 26 to "see Section 27 05 33". There are main sections, as in the following:

- 27 00 00 General Communications Requirements
- 27 20 00 Data Communications
- 27 30 00 Voice Communications
- 27 40 00 Audio – Video, MATV Communications
- 27 50 00 Monitoring Systems Communications

Each of these main sections will have many sub sections. The Construction Specifications must include all sections and sub sections that will have any active role in the project and only the specifications related to the project. Each section shall be formatted with:

Part 1 General

- Summary

- Codes, Standards, Guidelines (this Standard)
- Definitions (Warranties, Installers Certifications and Qualification, Segregation of Work:
- Electrical vs. Telecom ,Telecom vs. Fire Alarm, Security AV etc.)
- Submittals, product info and shop drawings

☒Part 2 Products

- List out specific products with manufacturer and part number

☒Part 3 Execution

- General installation instructions
- Specific instructions per product

Examples of Specific Sub Sections to specified:

- 27 05 26 Grounding and Bonding
- 27 05 29 Hangers and Supports
- 27 05 33 Conduits and Back boxes
- 27 05 36 Cable trays
- 27 05 53 Identification
- 27 06 00 Schedules for Communications
- 27 08 00 Commissioning and Testing
- 27 11 00 Equipment Room
 - 27 11 13 Entrance Protection
 - 27 11 16 Racks and Frames
 - 27 11 19 Termination Blocks and Patch Panels
- 27 15 00 Horizontal Cabling
 - 27 15 00.19 Data Cabling
 - 27 15 43 Faceplates and Connectors

2.5 T-Drawings

Telecommunications drawings shall be identified as “T” series (Telecommunications) drawings in the approved construction drawings, separated from “E” (Electrical) drawings. The T-series drawings shall include:

- ☒Floor layout, showing work outlets, cable path (j-hooks or cable tray, horizontal and riser), sleeves, conduits.
- ☒Legends, use industry standard symbols and legends, (Appendix G)
- ☒Telecommunications room layout / elevations (Appendix B)
- ☒Equipment rack layout (Appendix K)
- ☒Detailed work area outlet with labeling (Appendix L)
- ☒Riser diagram and cabling for voice, data and CATV (Appendix N)
- ☒Outside plant, cabling, methods and paths, with footages and bends (Appendix O)
- ☒Schedule of jacks and rooms (Appendix L)
- ☒Pull Box detail (Appendix F)

2.6 Bid Documents

Prior to bid, both the construction specifications (Division 27) and the T-Drawings must be approved by UTK OIT by formally approving the CD Drawings. Allow time for corrections to be made and not delay the project schedule.

2.7 Telecommunications Spaces (27 11 00)

2.7a Entrance Facility (EF) (27 11 00)

- An EF is a space where telecommunications outside plant (OSP) terminates to the inside facilities. The outside plant will most likely be fiber optics LAN, CATV coax, UTP telephone and MaxCell inner duct. (27 11 13)
- The EF may be in its own space or share a space inside an Equipment Room (ER).
- OSP cables routed inside a building are influenced by fire codes. The designer should be aware of, and adhere to, local codes, standards, and regulations that might be more stringent than UTK's recommendation.
- UTK recommends that OSP cable be terminated or transitioned to listed cable as close as practical upon entry to the building. In no case must this termination or transition exceed 50 feet from point of entrance for exposed cable. The designer may extend the point of entry by enclosing the unlisted outside cables in a rigid or intermediate metal conduit that extends beyond the wall or floor of the building and is properly sealed and bonded to a grounding electrode. At no point shall this cable be exposed prior to the termination point.
- The space needed for the EF is determined by the amount of terminations and if it is shared or not in the same room as the ER.
- The Entrance Facility shall be defined in specifications and T drawings as "EF".

2.7b Equipment Room (ER) & Telecommunications Room (TR) (27 11 00)

2.7b.1 ER/TR Space Allocation (27 11 00)

The ER/TR shall be rectangular in shape. Triangle, L-shaped, and curved walls are not acceptable. There shall be, at minimum, one ER per building and one TR per floor vertically aligned. Designs other than this arrangement must be approved via the Standards Variance form in Appendix C.

When the designer does not know the specific equipment that will be housed in the ER/TR, the designer can take the following steps in determining the size of the ER. Deduct all of the core areas from the total square footage the room will serve. If core areas are not known, then divide the total square footage by 20%.

- If the floor serving area is 5,000ft² or less, size the room 10'X8'
- If the floor serving area is 5,000ft² to 8000ft², size the room 10'X9'
- If the floor serving area is 8000ft² to 10,000ft², size the room 10'X11'
- If the floor serving area is 10,000ft² to 20,000ft², size the room 10'X15'
- It is not recommended by UTK OIT to house other services in the Telecommunications Rooms, due to network security.

If other services such as Fire Alarm panels or CBORD panels have to be housed in an ER or TR, (see Appendix C, Standards Variance Form) increase the size of the room 20%.

Equipment not related to the support of the ER/TR (e.g., piping, ductwork, pneumatic tubing, etc.) shall not be installed in, pass through, or enter the ER/TR.

Ceiling heights in an ER/TR is recommended to be 10' maximum. Network racks are 7' tall, so an 8'6" ceiling is recommended to accommodate cable tray and lighting. No false (lay-in tile) allowed in ER/TR.

Doors shall be a minimum of 36" wide and 7'6" tall. Doors must swing out of room or increase room size 3'. Floors are to be light in color and be either VCT or treated /painted concrete to prevent dust and enhance lighting. There should not be any windows in an ER/TR. If there is, they must be sealed to prevent opening and equipped with blinds. When generator power is provided to the building: All power, including power to all mechanical systems, in the ER/TR shall be installed to the buildings generator. All electrical outlets connected to the generator must be red in color with red faceplates. Circuit ID to be labeled on faceplate for all electrical outlets.

2.7b.2 ER/TR Layout (27 11 00)

There will be a minimum of two network racks with 6 inch deep vertical wire management per ER/TR, each rack has a footprint of 2'X2' and shall be bolted and bonded together. One rack is for cabling and the other for equipment. There shall be a minimum of 3 ft. clearance around all sides of the connected racks, measured from equipment mounted on wall, not the wall itself. Install appropriate 48-port patch panels and fiber optic patch panel in the cabling rack. There shall be horizontal wire management for patch panels, one installed above and the other underneath the patch panel. When determining the port quantities add 25% for future growth. A minimum of 18" wide ladder or basket cable tray shall be installed around room and to each rack. All fiber patch panels are to be mounted in the top of the rack with the equipment. Reference Appendix B.

All walls shall be covered with ¾" Fire Rated Plywood. The contractor shall be responsible for getting the plywood approved by the fire marshal before painting. See Appendix A for paint part number. Plywood shall be above electrical outlets (17" above finished floor typical) and extend to above cable tray. Different layouts for traditional phones and VoIP. Terminate traditional on plywood with 66 blocks. VoIP, terminate on patch panels below the network patch panels.

2.7b.3 ER/TR HVAC (23 82 19)

Today's network equipment consumes more power and generates more heat than yesterday's equipment. It is safe to say tomorrow's equipment will also increase power and heat from today's equipment. It is important to design for future growth of added equipment and network equipment upgrades. Design for a minimum of 5,000 BTU's from equipment, for up to 144 data outlets, add 1,000 BTU's for every 48 additional outlets served. HVAC shall be provided on a 24 hours-per-day, 365 days-per year basis. A stand-alone unit should be considered. When building is being backed up by generated power, it is required that the ER/TR's HVAC be tied

into the backup power, to keep the network and telephones working during a power outage.

- The temperature and humidity shall be controlled to provide continuous operating ranges of 68° F to 77° F with 40% to 55% relative humidity.
- The ambient temperature and humidity shall be measured at a distance of 5 ft. above floor level, after equipment is in operation, at any point along an equipment aisle centerline.
- When a UPS system is installed in the ER, the engineer will need to factor in the units BTU's.
- The ER/TR shall have positive air pressure with at least one air change per hour.

2.7b.4 ER/TR Power Requirements

- It is required that the electrical feed to the ER/TR be backed up by a generator, including all convenience outlets to conform with current NFPA code.
- Outlets and faceplates with a generator feed shall be red and labeled with the panel designation and breaker position of the servicing electrical panel..
- A separate supply circuit serving the ER/TR shall be provided and terminated in its own electrical panel inside the ER/TR.
- A minimum of two dedicated non-switched 3 wire 12 gauge single phase 120V ac 20amp duplex electrical outlets for equipment power, each on separate branch circuits. These outlets shall be mounted one each above each rack. **Note: A twist lock receptacle may be required.**
- Separate quad 120v ac convenience outlets for tools, test equipment etc, are to be placed at maximum of 6' (wall space) intervals around perimeter of room and below the plywood.
- Grounding and bonding shall be in accordance with ANSI J-STD-607-B and NEC 2011.
- Follow the manufacturer's recommendation for power needs of a UPS system.

2.7b.5 ER/TR Lighting

- Provide a minimum of 500 lux (50 foot-candles) measured 3' above finished floor.
- Locate light(s) 8.5' above finished floor.
- Power for lighting should not come from the power panel located inside the ER.
- At least one light is to be powered from generator.
- The walls and ceiling of the ER/TR shall be painted in light colored paint to enhance lighting.
- Coordinate the lighting layout with equipment layout, especially cable trays.

2.7c Telecommunications Enclosures (TE) (27 11 16)

A TE should serve an area not greater than 3600ft² and only to be used if a TR is not available or impractical. UTK OIT will determine the size and if a TE is to be used. The TE is not to be installed in furniture systems. The TE should be accessible and controlled against unauthorized access. If active equipment is to be housed in the TE:

- A minimum of one dedicated 120v, 20 amps, and non-switched, duplex electrical outlet receptacle should be provided.
- Sufficient number of air changes. Refer to equipment manufacturer for Standards.
- Must be bonded and grounded per ANSI J-STD-607-B.
- Doors hinged or removable to open at least 90°.
- Light measured within the TE should be a minimum of 500 lux (50 foot-candles).
- TE's must not be used in lieu of a TR on a given floor.

2.8 Telecommunications Pathways (27 10 00)

When designing a telecommunications pathway system, it is important to consider the design's ability to:

- Accommodate cabling changes
- Minimize occupant disruption when pathways are accessed
- Facilitate the ongoing maintenance of cabling

The designer should locate telecommunications pathways away from sources of Electromagnetic Interference (EMI), including:

- Electrical power cables and transformers
- Radio frequency (RF) sources
- Motors and generators
- Induction Heaters
- Arc welders
- X-Ray equipment
- Photocopy equipment

The designer should plan for a pathway capacity that accommodates a minimum of three cables per every WAO. Although a minimum of three cables is required, additional capacity would facilitate additions and changes to user needs and as applications evolve.

2.8a Conduits and Sleeves (27 05 28.33)

- Vertically aligned TR's with connecting sleeves are the most common type of backbone pathway.
- There shall be a minimum of three 4" conduit sleeves between each TR. (one filled with 3 3X3 MaxCell, each with their own color ID).
- No more than two 90° bends or a total of 180°
- Be less than 100' in distance

- If over 100' and or more than 180°, install a 31"wide X 60"length X 8"deep Pull Box (PB).
- The PB needs to be located in an accessible area.
- A PB is not to be used in lieu of a bend. Conduits are to enter and exit the PB in an aligned fashion.
- Empty conduits over 1" shall have a minimum 3/8" nylon rope pull line rated for 200lb. test. Conduits 1" and less shall have a polyline (Greenlee 430) installed.
- If more than 1 conduit in a room, install different colored polyline or rope.
- Conduits in the EF/ER/TR shall extend at least 3" and no more than 4" from floor, wall or ceiling.
- Adhere to the BICSI TDMM for conduit fill capacity.
- All WAO are to be fed within a minimum of 1" metal conduit. Consult UTK OIT on conduit sizing prior to design installation.
- All conduits must be installed per NEC 2011 and be terminated into a box or bushing prior to cabling.
- When determining the size conduit sleeve from corridor to office or room, add up all the WAO and times by three to get the number of cables and design for 40% fill. Minimum conduit sleeve (only 1 WAO) is 1". Multiple conduit sleeves are acceptable.
- All conduits shall be labeled, to/from.
- Conduit interior and exterior shall be fire stopped to meet AHJ approval.

2.8b Cable Trays (27 05 28.36)

Most installations will require a minimum of 18" wide cable tray. All ER/TR's shall have cable tray around perimeter of room, with branches off to each network rack and bonded to an approved ground. All structured cabling shall be installed in cable tray. Should any installation not support a cable tray installation then j-hooks will be used. A variance form, see Appendix C, will be required should J-hooks not be in the original designed. No more than 40 or more cables shall have multiple J-Hook paths. Cable tray shall be located a minimum of 3" above ceiling tile and have a minimum of 12" of unobstructed access above tray. When designing the layout of the cable tray, the designer should ensure that other building components (e.g., lighting fixtures, structural supports, air ducts) do not restrict access to the cable tray. The use of wire basket tray is an allowed substitution in lieu of cable tray for horizontal cabling.

2.8c J-Hooks (27 05 28.29)

J-Hooks are only to be used when cable tray installations cannot be used. Follow the manufacturer's specification on sizing J-Hooks. Regardless of the J-Hook's manufacturer's specifications, no more than the maximum of 40 cables is allowed in any J-Hook. When there are more than 40 cables, then cable tray, wire basket or multiple J-Hook paths are required. Space J-Hooks 4' to 5' and anchor J-hooks to studs.

2.9 Outside Plant (OSP) (27 05 43)

Before designing any OSP, the designer and or consultants will need to meet with UTK OIT for system requirements and methods. Most OSP at UTK is underground and in conduit.

Aerial and direct bury cables must be prior approved by UTK Telecommunications.

Underground requirements:

- 5" PVC Schedule 40 conduit only between Handholes (HH) and into buildings.
- 5" PVC Schedule 80 conduit under parking lots, streets, and driveways encased in concrete with warning tape on top of encasement.
- A minimum of 30" from top of conduit to finished grade.
- Minimum of 12 "separation from electrical power, 24" from steam lines.
- Minimum of four 5" conduits from Handholes (HH) to HH with 2 of the four conduits to have 4 3X3 **DETECTABLE** MaxCell installed.
- Minimum of three 4" conduits from HH to Building. UTK OIT will determine if more are required. At least one of the 4" conduits is to have 3 3X3 **DETECTABLE** MaxCell installed. Each MaxCell is to have different color ID markings and be locatable. (Plastic flexible inner duct not allowed).
- All conduits (including when filled with MaxCell) are to have a pull rope (no strings) installed.
- Conduits entering the buildings must be sloped away from building.
- HH's are to be manufactured by Quazite, open bottom (on top of 4" of rock), and with a minimum size of 30"X 48", cover labeled "Communications".
- Cover to have pull slot with center pin.
- HH covers are to be heavy duty and be traffic/drive over rated.
- Manholes shall a minimum of 7'X7'X7" inside dimensions and should be manufactured in top and bottom halves. Each manhole shall be equipped with steps and ladders. They shall have racks in all 4 corners mounted to corner brackets and 2 racks equally spaced on each side wall which are mounted on S brackets.
- HH's are to be installed at a maximum distance of 150' intervals for straight runs. This distance could be shorter after calculating bends and cable pulling tensions.
- No 90° bends in conduit. Communications sweeps are to be used.
- No "elbows or LB's" (Smart LB allowed, see appendix H), terminate conduit in an appropriate sized pull box (PB).
- When tying into an existing HH, first consult with UTK OIT to determine if a HH needs to be replaced with a larger size.
- When entering a HH, enter at bottom, do not drill or punch holes in sides of HH. Any exceptions to this must be cleared with UTK Telecommunications. A HH is not to be used in lieu of a bend. See Appendix F & F1.
- Conduits are to be free of debris and water. Seal conduits with pliable / non-hardening duct seal to keep out rodents and moisture (Ideal 31-605 or Gardner Bender GB-DS-110N or equivalent).
- Cabling is to be neat and professional inside HH & PB's. Route and secure cables around edges to free up room for future cabling.

- All cables are to be labeled inside HH or PB. Consult UTK OIT.
- Every other HH is to have a 25' maintenance loop for fiber optics. Secure loop to side of HH.
- Install "Caution Telecommunication" detectable Orange tape, along the cable pathway 12" below the final grade.
- When splicing is necessary; use approved splicing methods and enclosures. All coax connectors are to be enclosed with heat shrink, with at least 2" of shrink tube covering outer jacket. Use flame spread head to avoid scorching and melting center dielectric.
- Consult with UTK OIT before any splicing is designed or requested.
- Before backfill, all underground installations must pass UTK OIT inspections.

2.10 Horizontal cabling (27 15 10)

2.10a 100 ohm UTP CAT6 (27 15 00.19)

All new construction and full remodels are required to use Cat6 cabling for both voice and data.

Prior to design, the designer and or consultant must meet with UTK OIT to determine applications, methods and material. The maximum **cable distance** from the ER/TR to the WAO is 90m (295'). When deductions are made for mandatory minimum slack, the cable distance is approximately 85m (281').

- Cable slack in the ER/TR, minimum of 3m (10'). Above WAO (in the ceiling), 1m (3.28'), and at the WAO for termination 8". Cable slack should not be stored in bundled loops. Cable loops have a degrading effect on cabling performance. Cable slack should be stored in an extended loop or in a figure-eight configuration.
- All terminations shall be done to **T-568A** scheme.
- J-Hooks allowed only when cable tray cannot be used
- No splices in telecommunications cabling.
- Flexible metallic conduit or plastic tubing not allowed.
- No ty-wraps in ER/TR - use Velcro strips.

Any use of ty-wraps must be approved by the UTK OIT Telecommunications group.

2.10b Coaxial Cable (27 15 33)

All CATV installations shall comply with FCC Part 76 signal leakage requirements. There shall not be more than two CATV amplifiers in cascade in a building. Design the CATV system to a minimum of 1000MHZ. Design for range of 3dBmV to 10dBmV signal at the CATV outlet. No more than 17dBmV signal on an F-fitting. All CATV drops are to be home run from TR to outlet, no series wiring.

2.10c Work Area Outlets (WAO) (27 15 43)

4 ports, office white faceplates are the standard faceplate used in Administration, Classroom, Mechanical, and Building Automation spaces. 2 port flat faceplates are used in student rooms. The use of other type or color faceplates will be determined on a case by case basis and shall have prior approval from OIT. UTK has standardized on the colors of the jacks. All Cat6 data jacks are to be yellow. Special circuits are to be green.

2.10d Office Space

Each office space is to have a minimum of two WAO's, each with 3 cables as specified by UTK OIT fed within a 1" conduit. Cable offices by, routing cable to center of office before installing to WAO so the cables can be used in either WAO. Department Heads that will actually occupy the space will need to be consulted with to insure their needs are met. Network printers and fax machine locations often get overlooked.

2.10e Modular Furniture

Telecommunications and Power distribution planning should be coordinated to avoid conflicting pathway assignments. Untried distribution or terminations strategies should be avoided. Permanent cables shall be installed only in or on permanent walls. All modular furniture shall be fed from a "Consolidation Point" (CP). No direct horizontal cabling. Locate CP in an accessible area free from workstations and heavy file cabinets. Cabling from CP to modular furniture shall be through a power pole or through the wall if not blocked from furniture. Do not block access to horizontal cabling pathways or outlets. No cabling or WAO allowed behind modular furniture. Label "Consolidation Point" with adhesive label on ceiling grid where the CP is installed. Designer must calculate the maximum cable capacity allowed in the modular furniture's raceway and feed with multiple power poles if necessary.

2.10f Classroom / Labs

The designer will need to consult with UTK OIT's Special Project Manager for design specifications for Classrooms and Computer Labs.

2.10g Residence Life (Housing)

Each student bed is to have one data cable. Each living room and bedroom shall have a minimum of one CATV outlet. All CATV outlets shall be coordinated with UTK Telephone Services. See Appendix A for data/phone and CATV faceplates and jacks. All RA and Hall Director housing units shall have in additional voice data outlets. These shall be coordinated with UTK Telephone Services. When there is more than one CATV drop in a Housing unit, residential wiring scheme is permitted for CATV. Run one CATV drop to unit and split signal to other outlets in unit through 1" conduits. Locate in wall box near electrical panel, secure splitter to back of box and bond to electrical panel with #14 AWG green insulated wire. The main entrances to a housing building shall be equipped with an outside weatherproof wall or pedestal mounted phone and located phone near card reader door access.

2.10h Conference Rooms

Each conference room shall have a minimum of two WAO on opposite walls consisting of three CAT6 and one CATV cable. Consideration should be given to floor mounted WAO under conference table for data, voice and multi-media to projector or screen.

2.10i Break Rooms, Lobby / Others

As a general rule, each break room area should have one wall mounted WAO (ADA compliant). The Department Head should be consulted with for specific needs in their space. Lobbies and corridors may have wall mounted courtesy phones. Locate courtesy phones near elevators and or near main entrances /exits.

2.11 Backbone Cabling

2.11a Copper riser cables

Copper riser cable sizes shall be determined on a per building basis. Copper riser cables shall be ARMM cable. The cables shall be bonded. These cables shall terminate on the backboard beside the entrance protectors in the ER. Cables are to terminate on rack mounted 110 panels in the TR.

2.11b Fiber optic riser cables

Fiber optic riser cables shall be riser rated single mode manufactured by Corning. Cables shall be terminated with Corning LC unicom connectors.

3. Construction / Installation Standards

3.1 Certifications and Professionalism

Installers shall be certified by the manufacturer of the system(s) they are installing and be able to certify the installation for the manufacturer's warranty.

Installers must have:

- The necessary tools and test equipment
- Trained technicians to operate the equipment
- Have the ability to test, record, and produce drawings
- Provide material that is new and free of defects, delivered to the job site in the original packing.
- It is recommended that a RCDD be assigned as a Project Manager. Installers to be professional in their interactions with Faculty, Staff and Students and in their appearance. No objectionable graphics or language on shirts.
- Follow Campus rules as in the No Tobacco and Parking Policies.

3.2 UTP / Coax / Fiber Optic Installation

Strictly adhere to the methods of ANSI/TIA/EIA, & BICSI.

- All UTP terminations are to be to the **T568A** wiring scheme.
- Installers are responsible when pulling cables through conduit or sleeves that are installed by themselves or others. Installations that do not meet BICSI standards or NEC codes shall be redone at the discretion and direction of OIT. This includes,
 - Fill percent
 - Conduit size,
 - Number of bends between pull points,
 - Improper pull box and or size,
 - Conduit ends not terminated properly with bushings or connectors.
- Installers are responsible of maintaining proper clearances above ceiling tile and away from EMI sources.
- Installers shall not use other trade's pathways or allow them to use theirs.
- Before any terminations and installation of equipment, the EF/ER/TR must be in its finished stage. Free of dust and debris with all walls and ceiling painted to finish coat and floors installed or treated. This will need to be coordinated with the building /project schedule for Fire Alarm, Elevator, Building Automation Systems and Access Controls testing, inspections, and certifications. Contractor is responsible for dust, debris, and moisture. After terminations and equipment are installed, the EF/ER/TR's door must be kept closed and locked at all times.
- With the installation of underground or buried fiber optic cables a trace wire shall be installed along the entire fiber optic cable route for use in active cable location. The trace wire shall be a #16 or larger AWG solid-copper. The trace wire shall provide a connection point for any future underground utility location equipment.

3.2a Inspections and Walk Through

- All work is subject to inspection and review at anytime by qualified UTK personnel.
- All rough in work will be inspected by UTK personnel before finished walls and ceilings are installed.
- Final walk through inspections must be done prior to turning in final documentation and test results. The preliminary documentations will be made available for review during this walk through inspection.
- Cables with visible defects, kinks, twists, crushed, cuts, or smashed will be replaced regardless if they pass tests.
- Installer must take reasonable steps to protect their installation in a construction environment. Free of dirt, defects and debris.

3.3 Commissioning and Documentation (27 08 00)

UTK OIT requires the newly installed infrastructure to be tested and certified. Follow the Standards of ANSI/TIA/EIA-568-C.1,2,3,4 for testing criteria of the permanent link. See Appendix D for approved test equipment to obtain a manufacture warranty. Testing shall commence only after all materials are permanently installed, adjusted, bonded and labeled. Installer must retest and save both the original and retested results when any of the above occurs. Testing shall commence only in a clean environment, free of moisture, dirt, dust, and debris. Terminations exposed to such environments after testing will require retesting. In addition to the cabling being commissioned and certified, the electrical grounding and bonding systems must also be tested and certified.

- The electrical contractor is responsible for testing the Alternating Current (AC) Grounding Electrode System.
- The telecommunications installer is responsible for testing the Equipment Grounding (Bonding) System.
- Refer to the BICSI TDMM current edition for approved test equipment and acceptable results.

3.3a Warranties (27 08 00)

UTK OIT requires all installations to have a 25-year warranty. This warranty shall include all types of telecommunications services such as Power over Ethernet (PoE) Voice over IP (VoIP), LAN Security Cameras, Wireless LAN, Fiber applications, and any future services that meet CAT5E or CAT6 ANSI/TIA/EIA and or IEEE specifications.

3.3b Test Results (27 08 00)

Follow the manufacturer's warranty submittals and submit a copy of all results (including CATV, Fiber Optics, and Grounding/Bonding) to UTK OIT before final certification.

- All UTP cable test results must be submitted in their original format from tester in electronic format
- CATV signal loss and attenuation, length, signal leakage report and document on spreadsheet,
- Fiber lengths, attenuation, OTDR trace, submit in their original format from tester. Tests must pass manufacturer's specifications as well as industry standards. Cables with visible defects and deformations such as, kinks, twists or crushed will fail and need to be replaced regardless
- of test results.

3.3c Administration / Labeling (27 05 53)

It has become more important to accurately document every outlet and every port, so the information can assist in a 911 data base. All WAO's, patch panels, 110 blocks, conduits, trays, backbone cables, grounding, and racks shall be labeled according to ANSI/TIA/EIA 606-A, Class 3 standards, with specific labeling scheme of UTK OIT. All labeling material, methods and scheme shall be submitted during the required submittal process. All labels shall be printed or generated by a mechanical device. Labeling is to include:

- Identifiers required in class 3 Administration
- “Caution Fiber Optic” Adhesive marker every HH. Label to include SM & MM fiber count and “to and from”.
- “Caution Fiber Optic” Adhesive marker every 50’ of exposed fiber in building (including in cable tray). Label to include SM & MM fiber count and “to and from”.
- OSP UTP cables shall be labeled with permanent and neat penmanship in every HH and EF with “to and from” and cable pair count.
- OSP CATV coax cables shall be labeled with permanent and neat penmanship in every HH and EF with “to and from”.

3.4 Firestopping

- Firestopping methods and materials shall meet approval of AHJ
- Firestopping around the conduits shall be elastomeric (permanent).
- Firestopping inside the conduit shall be pliable putty (removable).
- Firestopping shall be accomplished by listed and approved methods and materials.
- See Appendix J.

4. Other Telecommunications

4.1 Multi Media

Multi Media design, installation, materials and methods, shall be done to the standards of ANSI/InfoComm Audiovisual Standards. Designer shall consult with OIT staff regarding Multimedia requirements including:

- Cabinets
- Power requirements
- Network Requirements
- Projectors
- Lighting
- White Boards
- Document Cameras
- Overhead Speakers
- Multi Media floor outlet boxes
- Multi Media

4.2 Wireless LAN (27 21 33)

Most buildings on UTK’s campus will have access to OIT’s WLAN. WLAN is not intended to replace wired data WAO’s but to provide flexibility. Work is to be completed prior to design and installation of renovated buildings to ensure radio-frequency integrity, optimum location for coverage and to identify possible interference problems. A RF survey and design must be completed by OIT staff and should be done after 100% Design and Development and before 100 % Construction Documents. Each wireless access point shall be cabled with two data cables. Terminate cables above ceiling to a secured single gang box, with 10’ slack coiled in a figure 8. Horizontal cables shall not directly terminate to equipment.

4.3 Security Cameras

Camera type and placement on new and/or renovated buildings is to be coordinated with Emergency Management Director and OIT prior to final design. During construction, a site visit needs to be arranged with OIT for the exact location and height. This visit shall occur after wall studs are installed and before drywall installation or external facade. Provisions in design shall be made for the pathways and power requirements. Install and design per manufacturer's specifications.

4.4 Code Blue Emergency Phones (27 32 56)

Code Blue Emergency Phone's type and location will need to be coordinated with UTK's Emergency Coordinator/UTK Police Department in the design phase and specified in the construction documents. Install as per the manufacturer's specifications, including grounding with 5/8", 8' ground rod and bonding the electrical ground with the telecommunications cable's sheath and protector.

4.5 Elevator Phones (27 32 23)

Elevator phone cable shall be CAT6 and be protected in conduit from elevator control panel to the TR and terminated in network rack (demarcation point). Installation, testing, and labeling shall be consistent with material and methods found in this standard.

4.6 Building Access / CARDAX

Refer to Facilities Services and VolCard office on this item and follow their guidelines and specifications.

4.7 Building Control / BAS

Refer to Facilities Services on this item and follow their guidelines and specifications.

4.8 Fire Alarm Communications

Refer to Facilities Services on this item and follow their guidelines and specifications.

Appendix A

Material and Parts List

The following materials are to be used unless a timely submitted substitute is approved by UT OIT.

CABLES

- **CAT5E Cable** Mohawk, General, Commscope, Berk-Tek and Comtran
- **CAT6 Cable** Mohawk, General, Commscope, Berk-Tek and Comtran
- **Fiber Optic OSP Cable** Fiber and connectors shall be single mode manufactured by Corning
- **Fiber Optic Riser Cable** Fiber and connectors shall be single mode manufactured by Corning

- **Fiber Optic Horizontal Cable** Fiber and connectors shall be manufactured by Corning
- **Coax Horizontal---** to be determined on a per project basis.
- **Coax----** to be determined on a per project basis.
- **OSP Coax, Flooded-----** to be determined on a per project basis.
- **OSP Phone CAT3**, BSW (Buried Service Wire), Essex or General Cable PE89 and /or PE22 as determined by UTK OIT.
- **Riser phone CAT3-----**Copper riser shall be ARMM manufactured by General or Superior/Essex.
- **Inner Duct**, MaxCell 3X3, (Locatable for OSP), color ID

CONNECTORS

- **CAT5E Jacks**, Hubbell HXJ5EB or PANDUIT CJ5E88TGBU
- **CAT3 Jacks**, Hubbell HXJ3B or Panduit CJ66BUY
- **CAT6 Jacks**, Hubbell HXJ6Y or Panduit CJ688TGYL
- **Coax RG6 F-Fittings**, Thomas and Betts SNS1P6U (plenum SNS6PLA or Ideal 92-660)
- **Coax RG11 Fitting**, Thomas and Betts SNS11AS
- **Coax F-81 Jack** (Office only, not student rooms) Hubbell SFFEX or Panduit CMFEI
- **Fiber Optic Connectors** Corning Unicam LC connectors

CROSS CONNECTS

- **CAT6 Patch Panel** 48 port Hubbell Nextspeed Black HP648E or Panduit CP48WSBLY with CJ688TGYL jacks or Panduit DP48688TGY Punchdown Patch Panel
- **110 Blocks Rack Mount** 100 pair with wire management Hubbell 110RM series or Panduit P110B100R2Y
- **66 Blocks Wall mount** 50 pair Cat.5e with cover Hubbell HPW66M150C5 or Siemon M1-50
- **Fiber Optic Connector Housing**, Corning, Panduit, Hubbell
- **Fiber Optic Wall Mount**, Corning, Panduit, Hubbell
- **UTP Protectors (CAT3)** Circa 1890 BC1series

CABLE MANAGEMENT

- **Network Rack** with 6" Z-Channels,, Black, Hubbell Nextframe CS-1976 or PANDUIT CS1976 to our R2P 2 POST RACK, PLUS WMPVHC45E (NetRunner Vertical Cable Manager Front and Rear 45 RU).
- **Horizontal Management Rack Mount**, Hubbell HS23C or PANDUIT CMPHF2 and cover CMPH2C.
- **Cable Management Rings**, Hubbell MCCPSR4, PANDUIT CMPH1
- **Cable Management Troughs Wall Mount**, (110 blocks) Hubbell 110TR series or Panduit equivalent
- **Cable Tray, (for ER/TR)** Hubbell Next Frame, 18", "HL" Series, or Cooper B-Line SB17U18B
- **Cable Tray, (for corridors)**, Hubbell, 18", "HPW" Series, or Cooper B-Line SB17U18B
- **J-Hooks**, (up to 40 cables), Cooper B-Line BCH32 or Panduit JP2W-L20
- **J-Hooks**, (up to 10 cables), Cooper B-Line BCH12 or Panduit JP75W-L20
- **Equipment Shelf**, Hubbell MCCC series or Panduit equivalent
- **Work Area Outlet (WAO)**(Coordinate faceplate color with electrical faceplates)
- **Office/Classroom Faceplate**, 4 port, Hubbell IFP14W (WHITE) or Panduit CBEIWY (uses CHF2IW-X mini-com inserts) or Panduit CFPL4WHY MINICOM Faceplate
- **Office/Classroom Faceplate**, 6 port, Hubbell, IFP16W or Panduit CFPL6WHY

- **Office/Classroom Faceplate**, 9 port, Hubbell, IFP212W or Panduit CFPF12WH-2G
- **Student Room Faceplate**, 2 port, Hubbell, IFP12W, Panduit CFPL2WHY
- **HON Furniture Faceplate**, 2 port, Hubbell FP2BK (black), FP2GY (gray), Panduit CFFPA2BL (black), CFFPA2IG (gray)
- **Blank Faceplate inserts**, (White) Hubbell SFB series, Panduit CMBWH-X
- **Blank Faceplate inserts**, (Black) Hubbell SFB series, Panduit CMBBL-X
- **Blank Faceplate inserts**, (Gray) Hubbell SFB series, Panduit CMBIG-X

Miscellaneous

- **Firestop** 3M or Hilti “Moldable Pliable Putty” CP-618. *Tube putty and caulk that cures to an elastomeric solid is not approved in conduit.* Hilti FS-ONE around the conduit.
 - For wall pass through, EZ-Path product shall be used.
- **Fire Retardant Paint**, Benjamin Moore M59-220 (white), up to 2 oz. of tint allowed per gallon.
- **Telecommunications Grounding Busbar**
 - (Rack Mount) Hubbell HBBBHR19KT, Panduit RGRB19Y (THREADED) OR RGRB19CN FOR CAGE NUT RAILS.
 - (TGB) Hubbell HBBB14210A, Panduit GB2B0304TPI-1
 - (MTGB) Hubbell HBBB14416G, Panduit GB4B0612TPI-1
- **Power strip**. (for network rack), Panduit or Hubbell HPWPWR, Panduit CMRPSH15
- **Emergency Phone**, Code Blue Emergency Phones with keypad and directory plate. CB1D-PAS, with IA4100 / FP2-K for pedestal. Use the CB2E-PAS for wall phones with a IA4100/FP2-K phone.
- **Handhole (HH) Pull Box**, as manufactured by Quazite- to be determined on a per project basis..
- **Splice Box** Quazite. Lids are to be identified with “Communications” and have pull slots center pins.
- **Splice Enclosures**,
 - For Copper 3M 505 series
 - Fiber Optics, 3M
- **Duct Seal**, Ideal 31-605, Gardner Bender GB-DS-110N or Panduit DS5 Duct Seal

Please note: All crosses are functional equivalents and may not be exact.***

*** All crosses are based upon description and may not be exact*

Appendix B
TR Layout

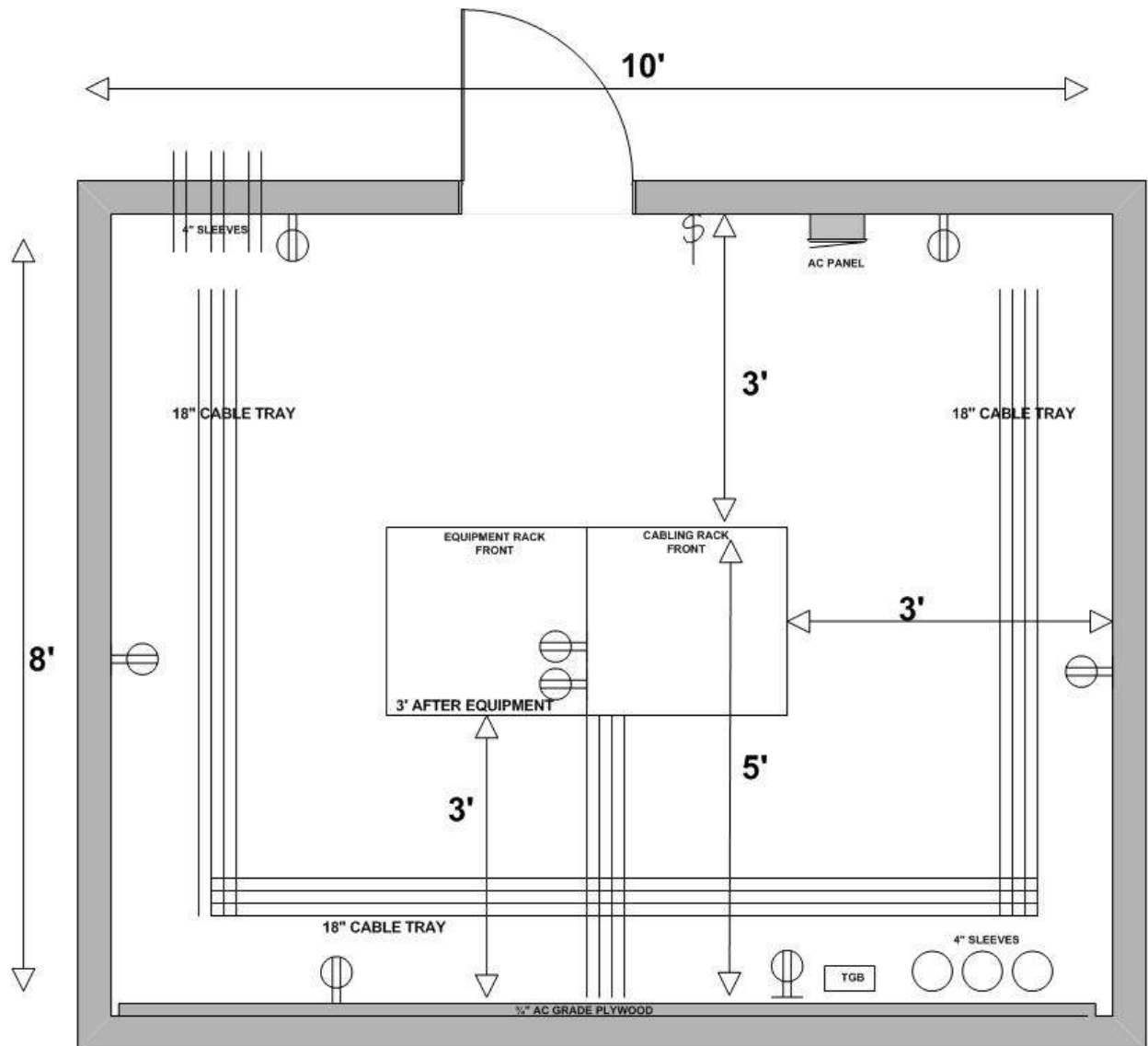

**Appendix C
Standards Variance Form**

UTK Telecommunications Standards Variance Request Form

Complete this form and submit to the UTK Project Coordinator. UTK OIT will review the request and either accepts, modifies or denies the variance and will notify the UTK

Project Coordinator.

Project Name: _____ Date: _____

Requester: _____

Company: _____

Title: _____

UTK Project Coordinator: _____

Reason for Variance: _____

Is the variance requested due to (check all that applies?)

Cost___ Amount \$_____

Schedule Impact___ Days impacted _____

Suggested Remedy(s):

.....

To be completed by UTK OIT

Comments and or suggestions:

This request has been (circle): Approved Modified Denied

Signature _____ Date: _____

Appendix D Registration for Installation Warranty

Mission Critical Warranty Program



Our MISSION CRITICAL® Warranty means superior network protection for you.

- Start with Hubbell Premise Wiring connecting hardware
- Use cable from Hubbell or a Hubbell cable partner
- Have your structured cabling system installed by a Hubbell Certified Installer

That's all it takes and you're protected. That's how simple it is, guaranteed!

The Hubbell MISSION CRITICAL® program gives you an assurance of system success with a 25-year guarantee on the components, performance, and installation integrity of your structured cabling system.

Panduit Certification Plus System Warranty

Panduit also offers a complete Certification Plus System Warranty on eligible installations registered with Panduit. This warranty assures customers their registered structured cabling system's performance will meet all relevant cabling system standards for up to 25 years. To be eligible for the Certification Plus System Warranty, the system must be registered with Panduit, installed by a Panduit Certified Installer or a Panduit Project Authorized Installer, and must meet all program requirements. To learn more about Panduit's system warranties, please contact the Certification Plus System Warranty Program Manager. The Certification Plus System Warranty is subject to terms, conditions and limitations which can be seen on this sample [Certification Plus System Warranty Certificate](#).

Appendix E Grounding and Bonding



Grounding & Bonding Infrastructure

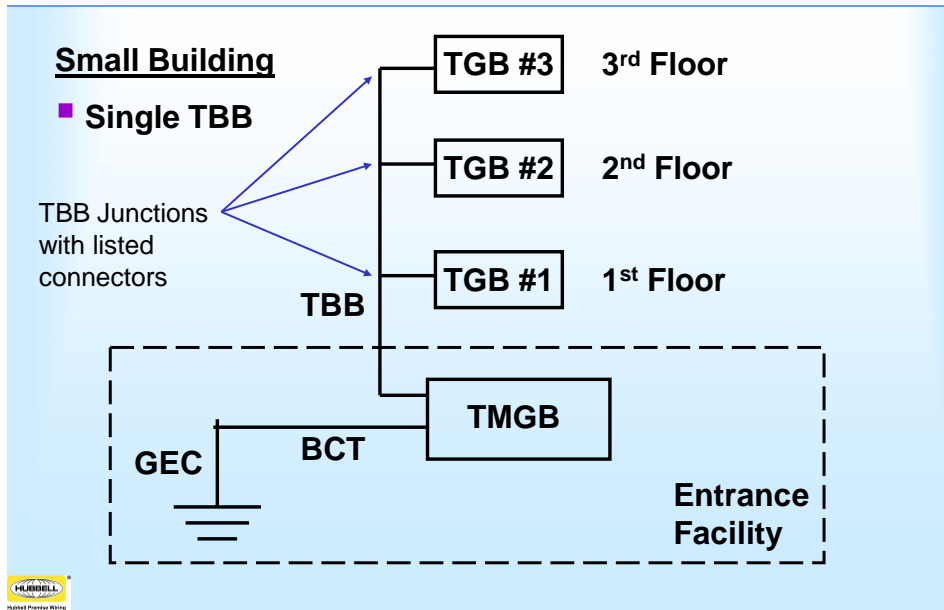

Appendix E-1
Telecommunications Grounding Bus Bar (TGB)

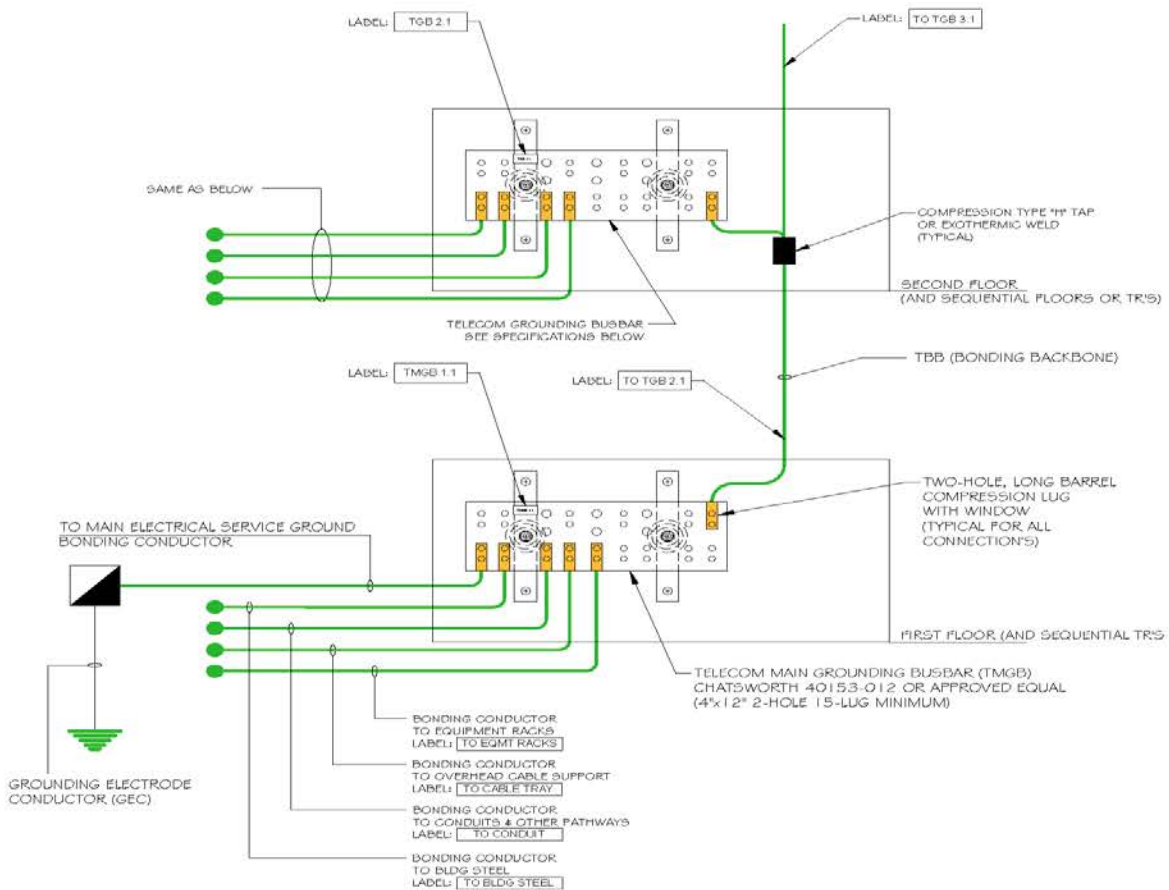

* ALL BONDING CONDUCTORS ARE GREEN-JACKETED #6 AWG COPPER. TWO-HOLE CONNECTIONS/LUGS ARE REQUIRED. ALL LABELS SHALL BE APPLIED WITHIN 2" OF LUG. CONSULT ETSU FACILITIES AND O.I.T. PRIOR TO GROUND BAR AND/OR CONDUCTOR INSTALLATION.

INTRA-BUILDING BONDING/GROUNDING RISER DETAIL
NOT TO SCALE

* FOR INFORMATIONAL PURPOSES ONLY

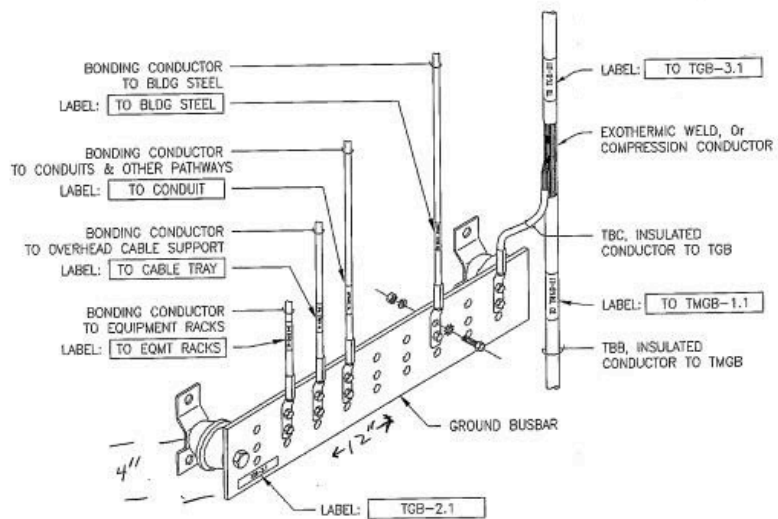

Grounding Busbar Example

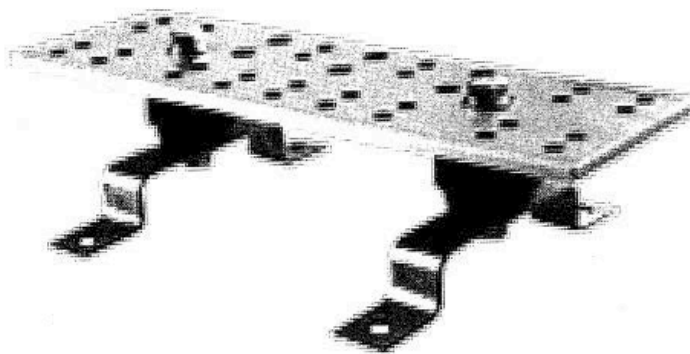

Appendix F Pull Box (PB) / Hand Hole (HH)

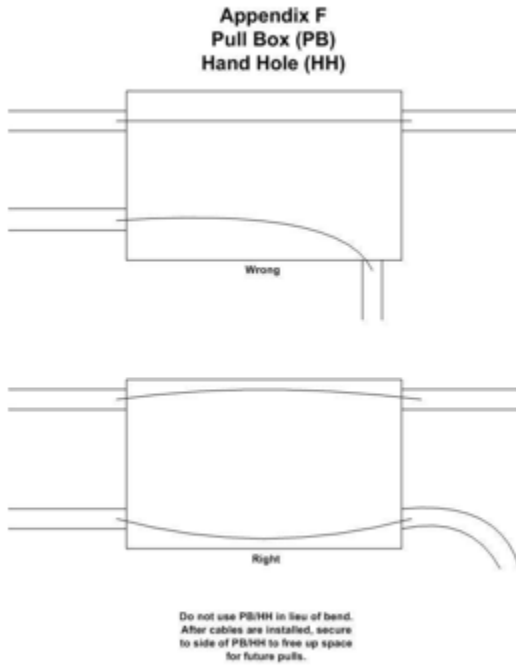

Appendix F-1 Pull Box Configurations

Pull Points or Pull Boxes for Conduits

Installing Pull Points or Pull Boxes

The ITS installer should install:

- Pull points or pull boxes in easily accessible locations.
- Horizontal cabling boxes immediately above suspended ceilings.

NOTE: The following pull point or pull box information applies to inside plant cables only.

For direct access to a box, provide a suitable, marked, hinged panel (or equivalent) in the suspended ceiling. This access panel can also serve as the cover for the box.

Figure 5.6 shows recommended box configurations.

Figure 5.6
Recommended box configurations

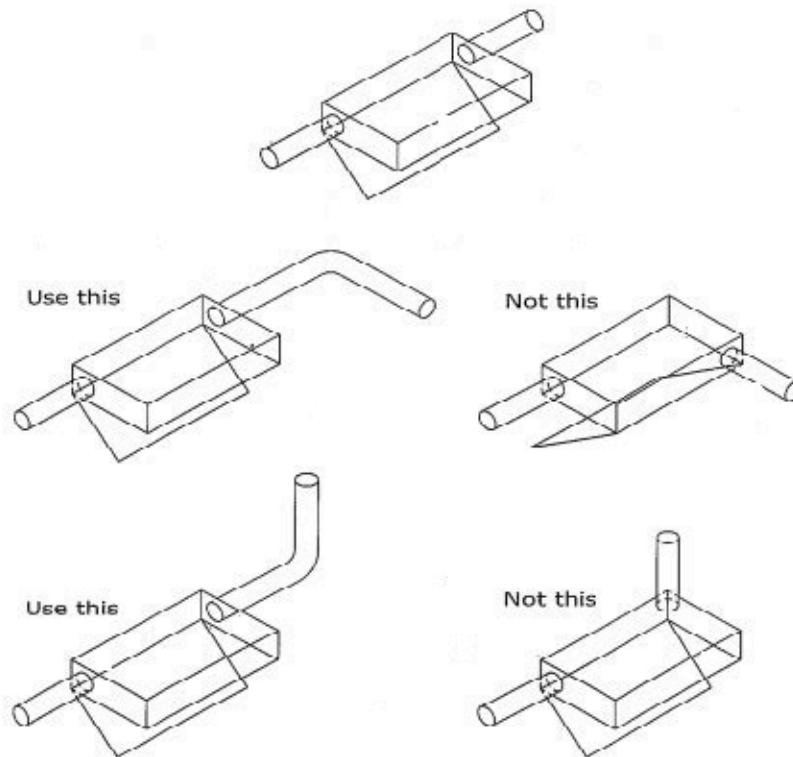

Appendix G Legends

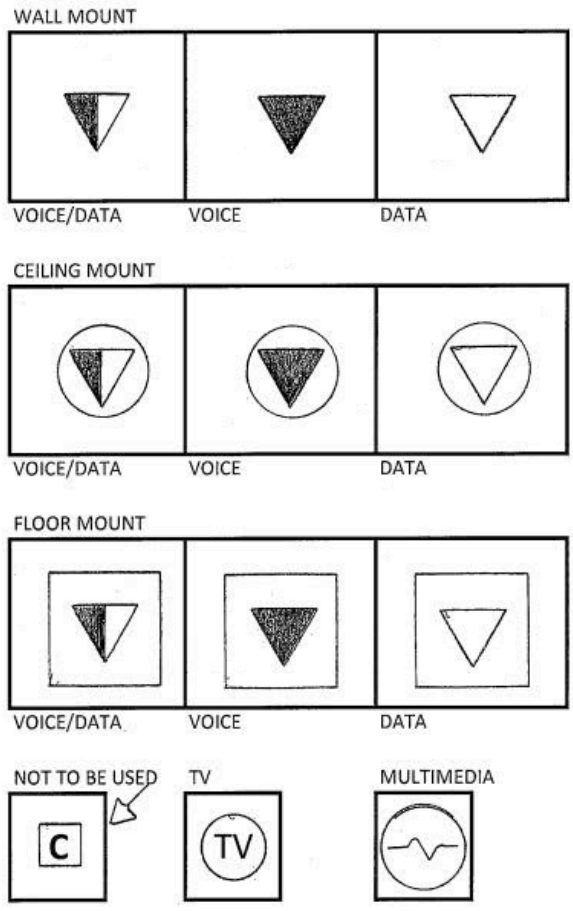

Appendix H
Smart Conduit Body

Smart Conduit Body - Telecommunications LB

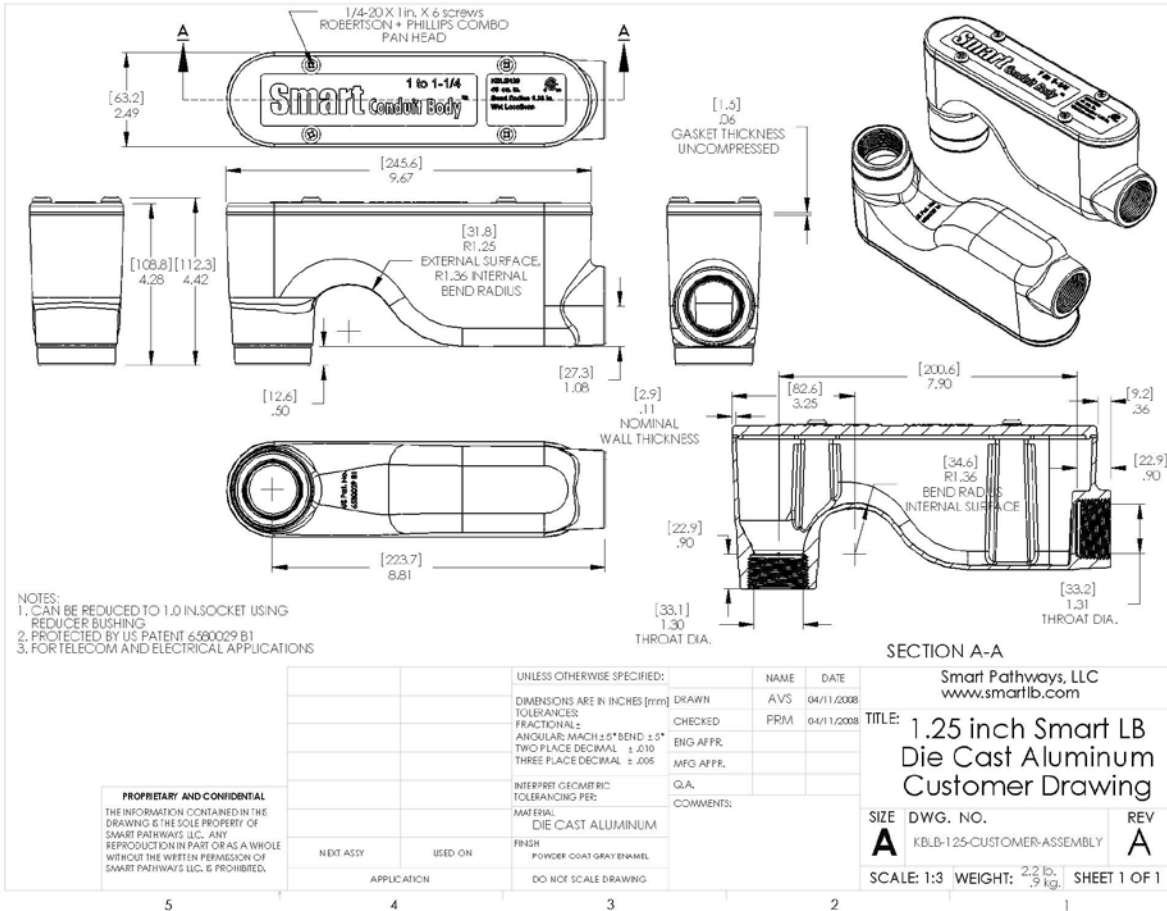

Telecommunications Enclosure

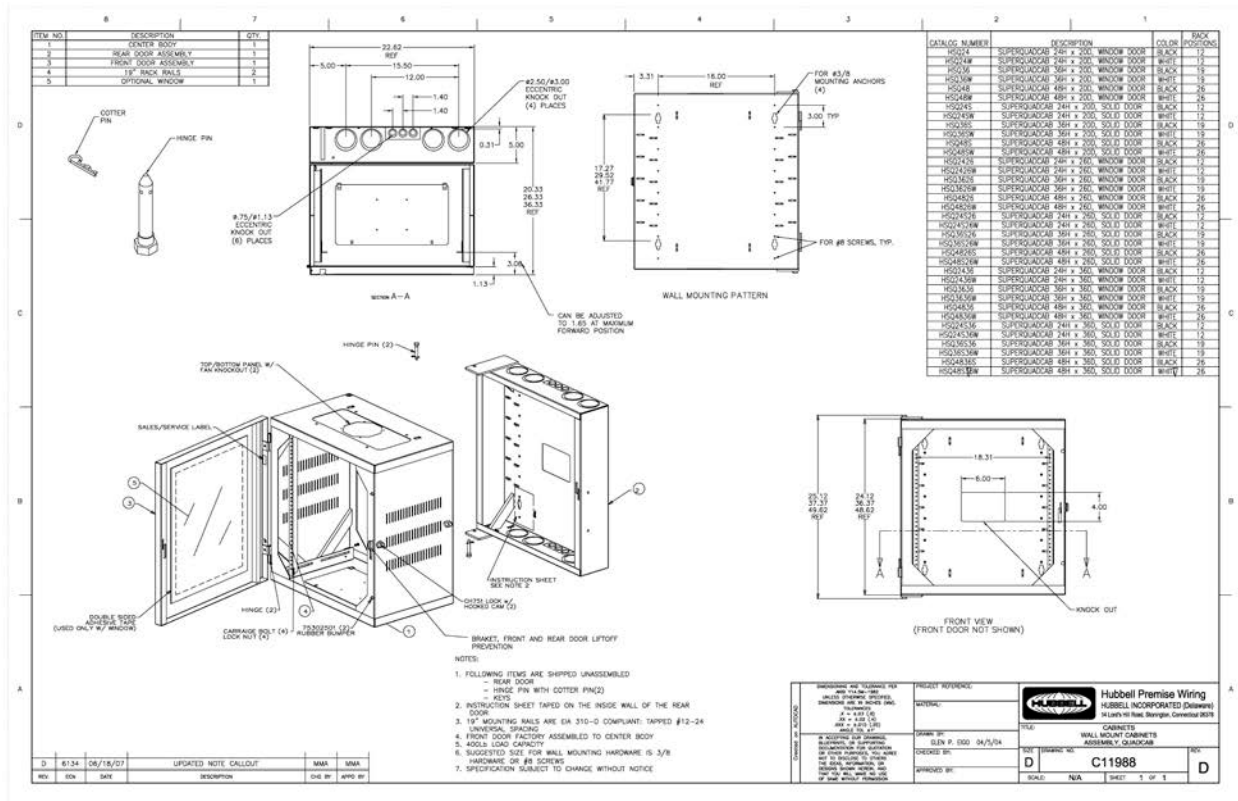

Appendix J
Fire Stop

Fire Stop
Pliable/Removable Inside
Stiff Caulk Outside



FS-ONE Caulk
Outside/Around Conduit
Permanent



CP-618 Putty
Inside Conduit
Removable



**Appendix K
Rack Layout**

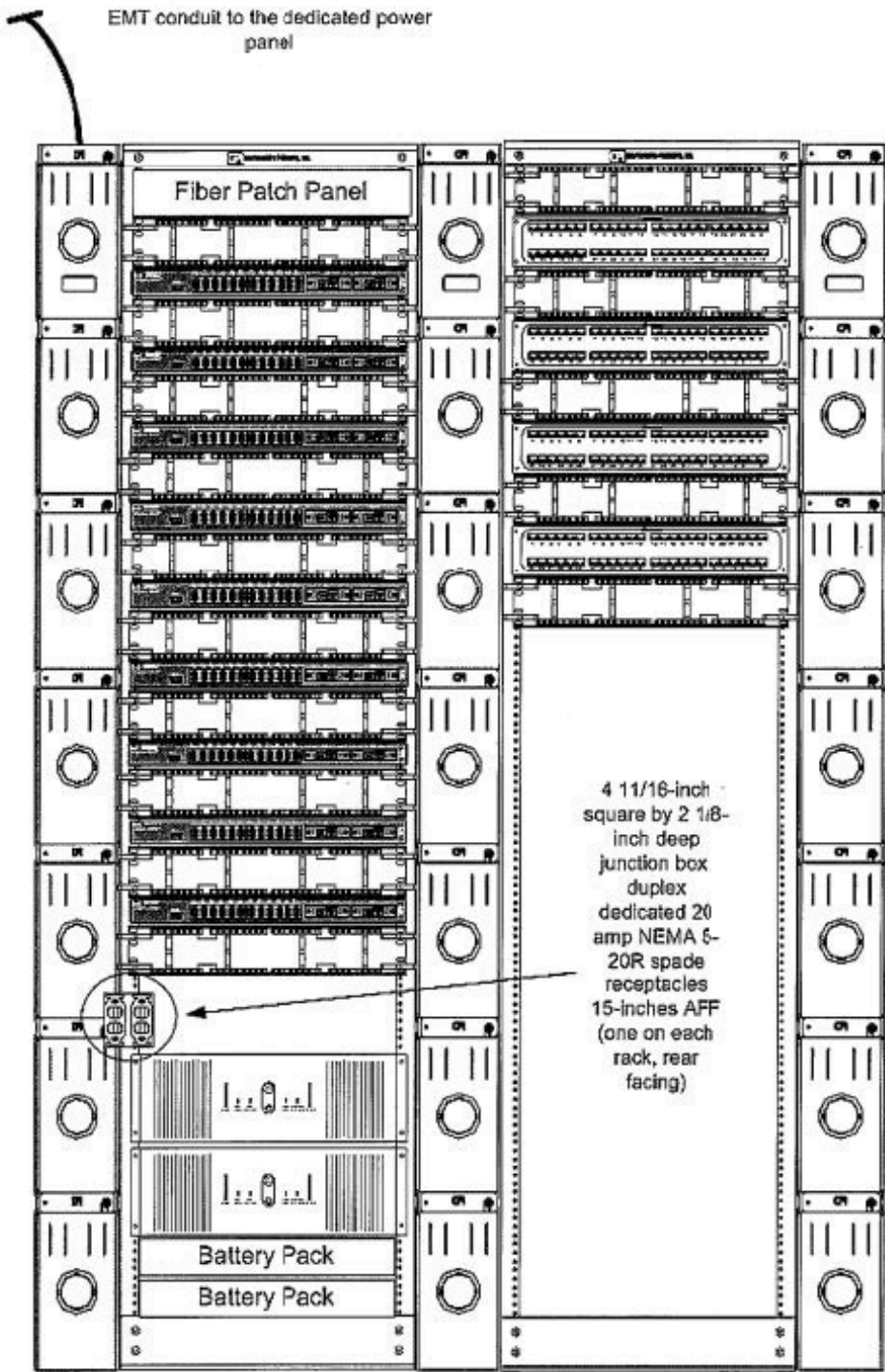

Drawing Not To Scale

**Appendix L continued
FACEPLATE**

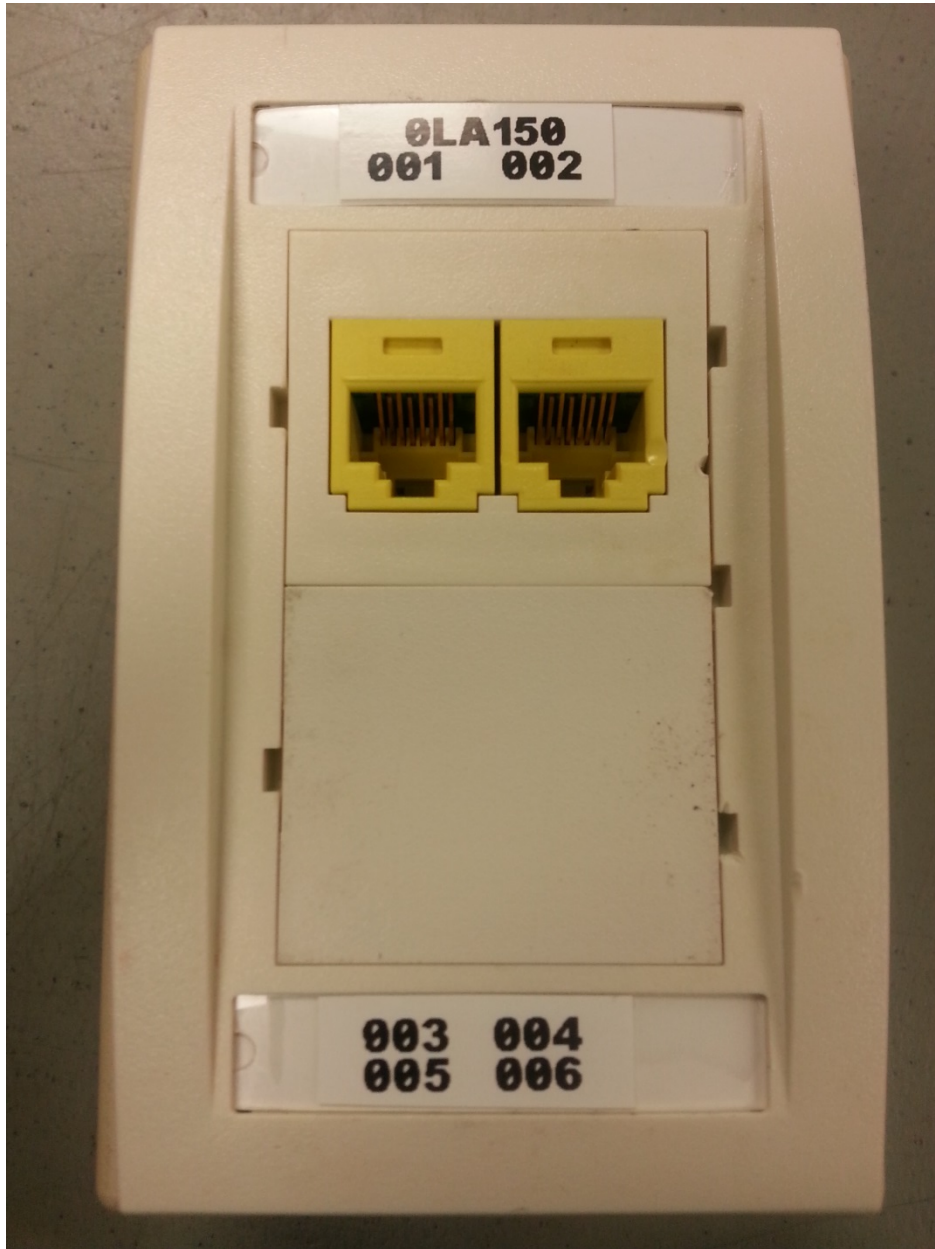

**OIT WILL PROVIDE THE LABELING SYNTAX FOR EACH BUILDING AND TR
WITHIN THE BUILDING!**

**Appendix M
Labels**

Detectable Underground Warning Tape

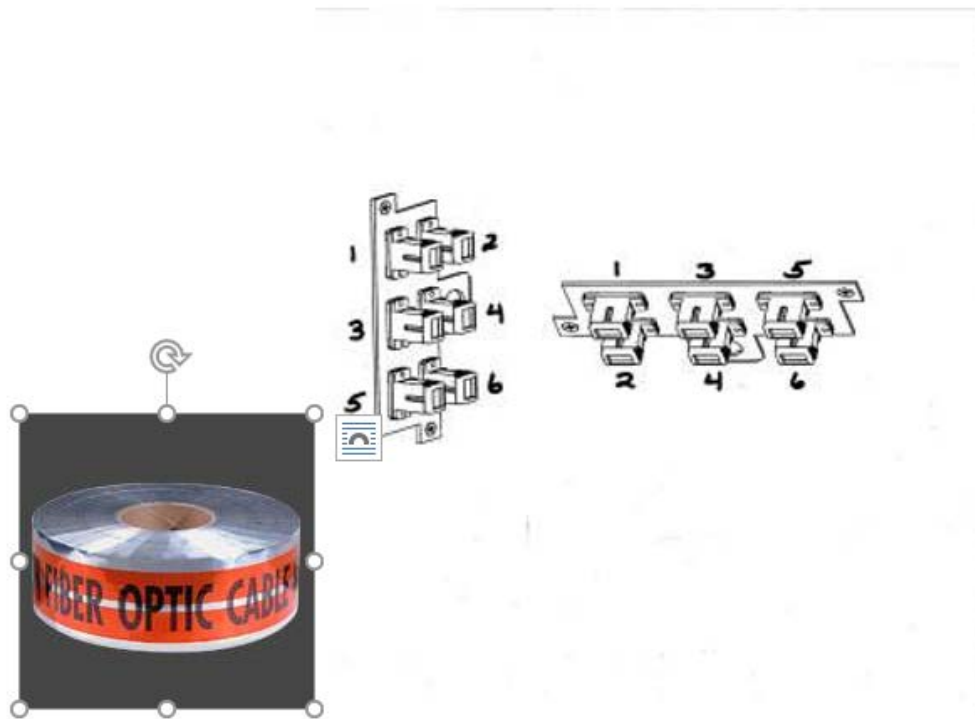

Detectable Underground Warning Tape

**Appendix N
Riser**

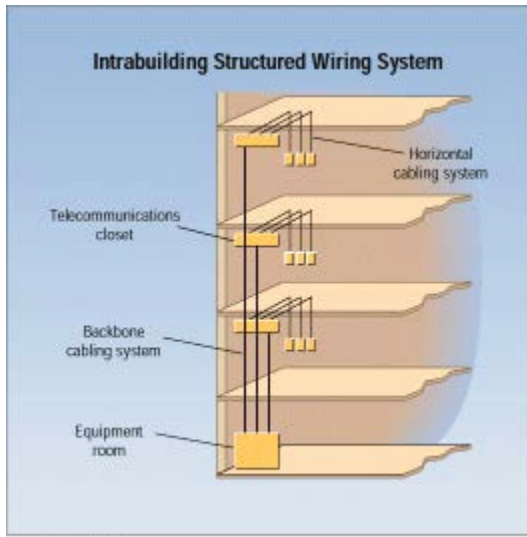

01 Design Fig.1

**Indicate where the penetrations are for floors and walls.
 Indicate on drawings, length, degrees of bends, location and size of pull
 boxes for every conduit/riser**

**Appendix O
 Outside (OSP) Plant**

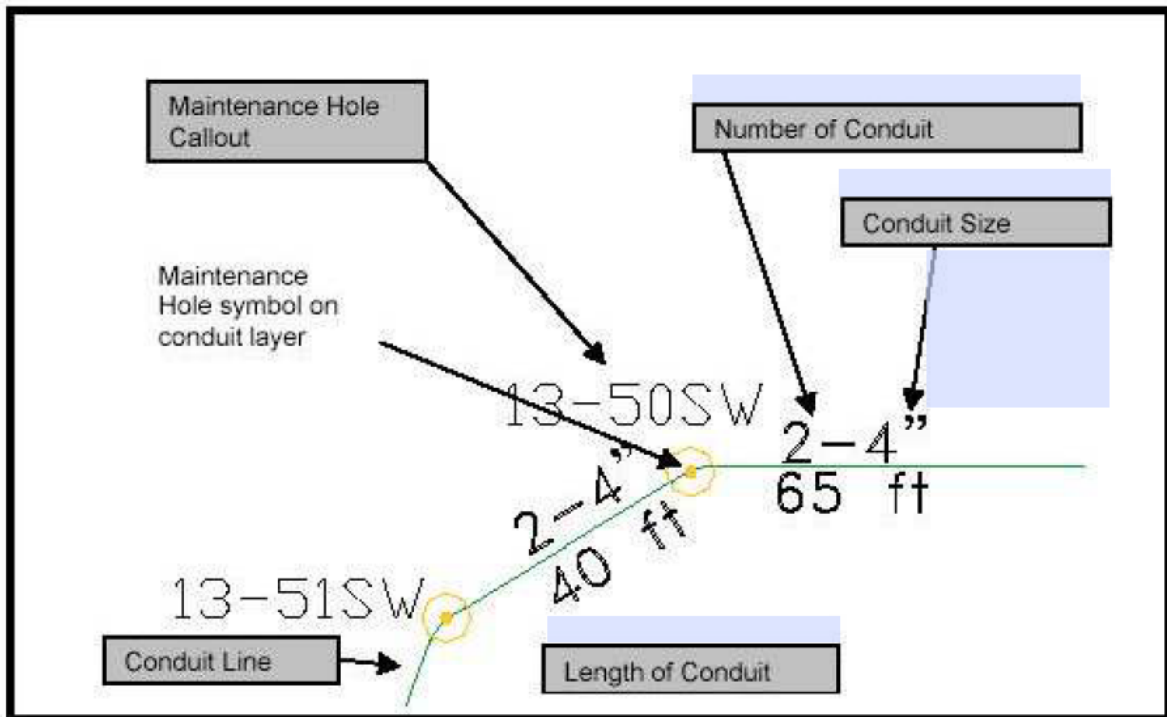

ABBREVIATIONS

AC alternating current
 ACR attenuation-to-crosstalk ratio

ADA Americans with Disabilities Act
ADO auxiliary disconnect outlet
ADSL asynchronous digital subscriber line
AHJ authority having jurisdiction
AIA American Institute of Architects
ANSI American National Standards Institute
AP access provider
ASTM American Society for Testing and Materials
ATIS Alliance for Telecommunications Industry Solutions
ATM asynchronous transfer mode
AWG American Wire Gauge
BAS building automation system
BC bonding conductor
BCD backbone conduit
BER bit error rate
BICSI Building Industry Consulting Service International
BNC bayonet Neil-Concelman
BOCA Building Officials and Code Administrators
BOMA Building Owners Managers Association
CATV community antenna television
CCTV closed-circuit television
CBC coupled bonding conductor
CBN common bonding network
CCA copper coated aluminum
CCITT International Telegraph and Telephone Consultative Committee
CCS copper coated steel
CD compact disc
CEA Consumer Electronics Association
CEC Canadian Electrical Code, Part I
CER common equipment room
CISPR International Special Committee on Radio Interference
CLEC Competitive Local Exchange Carrier
CPE customer premises equipment
CPU central processing unit
CSA Canadian Standards Association International
CSI Construction Specifications Institute
CTR common telecommunications room
CU copper
DC direct current
DOC Communications Canada
DIP dual inline package
DPST double pole, single throw
DSS digital satellite system
DSX digital signal cross-connect
DTE data terminal equipment
DUT device under test
DVD digital versatile disc
EDA equipment distribution area
EF entrance facility
EIA Electronic Industries Alliance

ELFEXT equal level far-end crosstalk
EMC electromagnetic compatibility
EMI electromagnetic interference
EMT electrical metallic tubing
ENT electrical nonmetallic tubing
EP entrance point
ER equipment room
FCC Federal Communications Commission
FDDI fiber distributed data interface
FEXT far-end crosstalk loss
FIPS PUB Federal Information Processing Standard Publication
FLS fire life safety
FOCIS Fiber Optic Connector Intermateability Standard
FTP foiled twisted-pair
FTR Federal Telecommunications Recommendation
HC horizontal cross-connect
HCP horizontal connection point
HDA horizontal distribution area
HDG heavy duty galvanized
HVAC heating, ventilation and air conditioning
IBC interconnecting bonding conductor
IC intermediate cross-connect
ICEA Insulated Cable Engineers Association
IDC insulation displacement contact
IEC International Electrotechnical Commission
IEEE The Institute of Electrical and Electronics Engineers
IFMA International Facility Management Association
ILD insertion loss deviation
IPC insulation piercing contact
IR infrared
ISDN integrated services digital network
ISO International Organization for Standardization
ITU-R International Telecommunication Union - Radio sector
ITU-T International Telecommunication Union - Telecommunication sector
LAN local area network
LCL longitudinal conversion loss
LCTL longitudinal conversion transfer loss
LEC local exchange carrier
LED light emitting diode
MAU media attachment unit
MC main cross-connect
MDA main distribution area
MDF main distributing frame
MH maintenance hole
MPD multiple plastic duct
MR mechanical room
MUTOA multi-user telecommunications outlet assembly
MUX multiplexer
N/A not applicable
NBC National Building Code of Canada

NCS National Communications System
NEC National Electrical Code
NEMA National Electrical Manufacturers Association
NEXT near-end crosstalk
NESC National Electrical Safety Code
NFPA National Fire Protection Association
NID network interface device
NIR near-end crosstalk to insertion loss ratio
NIST National Institute for Standards and Technologies
NRTL national recognized testing laboratory
NVP nominal velocity of propagation
OC outlet cable
OC outlet cable (570) or optical carrier (942)
OCC other common carrier
OSP outside plant
PBX private branch exchange
PCB printed circuit board
PD power device
PDU power distribution unit
PSACR power sum attenuation-to-crosstalk ratio
PSE power source equipment
PSELFEXT power sum equal level far-end crosstalk
PSFEXT power sum far-end crosstalk
PSNEXT power sum near-end crosstalk
PVC polyvinyl chloride
REA Rural Electrification Administration
RF radio frequency
RFI radio frequency interference
RH relative humidity
RJ registered jack
RMS root mean square
SAN storage area network
SCC Standards Council of Canada
SCTE Society of Cable Telecommunications Engineers
ScTP screened twisted-pair
SDH synchronous digital hierarchy
SFF small form factor
SIP IC Single Inline Package Integrated Circuit
SONET synchronous optical network
SP service provider
SRL structural return loss
STM synchronous transport model
STP shielded twisted-pair
SSTP screened and shielded twisted-pair
TBB telecommunications bonding backbone
TCL transverse conversion loss
TE telecommunications enclosure
TEF telecommunications entrance facility
TGB telecommunications grounding busbar
TIA Telecommunications Industry Association

TMGB telecommunications main grounding busbar
TP transition point
TR telecommunications room
TS telecommunications space
TSB Telecommunications System Bulletin
TU Thomas University
UL Underwriters Laboratories Inc
ULC Underwriters Laboratories of Canada
UPC universal product code
UPS uninterruptible power supply
UTP unshielded twisted-pair
WA work area
WAN wide area network
ZDA zone distribution area
WP waterproof outlet box
X cross-connect

Units of measure

A Ampere
dB decibel
°C degrees Celsius
°F degrees Fahrenheit
ft feet, foot
g acceleration of gravity (shown in Helvetica oblique for English measure)
g gram
Gb/s gigabit per second
GHz gigahertz
Hz hertz
in inch
J joule
kb/s kilobit per second
kg kilogram
kHz kilohertz
km kilometer
kN kilonewton
kPa kilopascal
kV kilovolt
kVA kilovoltamp
kW kilowatt
lbf pound-force
lx lux
m meter
mA milliampere
m/s² acceleration of gravity in SI (1g = 9.7536 m/s²)
Mb/s megabit(s) per second
MHz megahertz
mm millimeter
N Newton
nF nanofarad

nm nanometer
ns nanosecond
pF picofarad
ppm parts per million
sq in square inch
sq mm square millimeter
V volt
Vac volts alternating current
Vdc volts direct current
V rms volts root mean square
W Watt
 Ω Ohm

GLOSSARY

ablative: The development of a hard char that resists the erosion of fire and flames; a characteristic of a firestop when exposed to fire.

access floor: A system consisting of completely removable and interchangeable floor panels that are supported on adjustable pedestals or stringers (or both) to allow access to the area beneath.

access line: A telecommunications circuit provided by a service provider at the demarcation point.

access provider: The operator of any facility that is used to convey telecommunications signals to and from a customer premises.

access unit: A location that allows entry into the pathway system.

activation unit: A floor system device that contains all components necessary to provide service access.

active cross-connect: A facility enabling the termination of cable elements and their interconnection or cross-connection by electronic means.

adapter: A device that enables any or all of the following:

(1) different sizes or types of plugs to mate with one another or to fit into a telecommunications outlet,

(2) the rearrangement of leads,

(3) large cables with numerous conductors to fan out into smaller groups of conductors, and

(4) interconnection between cables.

adapter; optical fiber duplex: A mechanical device designed to align and join two duplex optical fiber connectors (plugs) to form an optical duplex connection.

administration: The method for labeling, identification, documentation and usage needed to implement moves, additions and changes of the telecommunications infrastructure.

aerial cable: Telecommunications cable installed on aerial supporting structures such as poles, sides of buildings, and other structures.

alternate entrance: A supplementary entrance facility into a building using a different routing to provide diversity of service and for assurance of service continuity.

alternate route: See **alternate entrance**.

antenna entrance: A pathway facility from the antenna to the associated equipment.

approved ground: See **ground**.

architectural assemblies: Walls, partitions, or other barriers that are not load bearing.

architectural structures: Walls, floors, floor/ceilings and roof/ceilings that are load bearing.

as-built: see record drawing

attenuation: The decrease in magnitude of transmission signal strength between points, expressed in dB as the ratio of output to input signal level.

auxiliary disconnect outlet: A device usually located within the tenant or living unit used to terminate the ADO or backbone cable. See DEMARC.

auxiliary disconnect outlet cable: In residential applications, the cable from the auxiliary telecommunications disconnect outlet/connector or the distribution device in a customer's premises to the backbone facility or the point of demarcation.

backbone: 1) A facility (e.g., pathway, cable or conductors) between any of the following spaces:

- telecommunications rooms, telecommunications enclosures, common telecommunications rooms, floor serving terminals, entrance facilities, equipment rooms, and common equipment rooms.
- In a data center, a facility (e.g. pathway, cable or conductors) between any of the following spaces:
 - entrance rooms or spaces, main distribution areas, horizontal distribution areas, telecommunications rooms.

backbone bonding conductor: A copper conductor extending from the telecommunications main grounding busbar to the farthest floor telecommunications grounding busbar.

backbone cable: See **backbone**.

backbone raceway: That portion of the pathway system that permits the placing of main and high-volume cables between the entrance location and all cross-connect points within a building and between buildings.

balance: Balance is the ratio of the differential signal output at either end of any pair to a common mode signal input, at either end of the same or a different pair, and vice versa, under specified termination conditions.

barrier (architectural): Architectural structures or assemblies.

bearing wall: A wall supporting a load other than its own weight.

binder group: One of two or more bound collections of pairs or fibers within a cable.

blank cell: The hollow space of a cellular metal or cellular concrete floor unit without factory installed fittings.

blended floor system: A combination of cellular floor units with raceway capability and other floor units with raceway capability, systematically arranged in a modular pattern.

bonding: The permanent joining of metallic parts to form an electrically conductive path that will ensure electrical continuity and the capacity to conduct safely any current likely to be imposed.

bonding conductor for telecommunications: A conductor that interconnects the telecommunications bonding infrastructure to the buildings service equipment (power) ground.

Bonding conductor: A conductor that interconnects the screened twisted-pair horizontal cabling infrastructure to the telecommunications grounding busbar.

braid: A group of non-insulated conductors interwoven to surround one or more insulated conductors.

bridged jack: A dual position modular female jack where all pins of one jack are permanently bridged to the other jack in the same order.

bridged tap: A connection that enables multiple appearances of the same cable pair at several distribution points.

building automation system: Equipment and telecommunications infrastructure that supports monitoring, control, operation and management of building services.

building backbone: Pathways or cabling between telecommunications service entrance rooms, equipment rooms, telecommunications rooms, or telecommunications enclosures within a building.

building core: A three-dimensional space permeating one or more floors of the building and used for the extension and distribution of utility services (e.g., elevators, washrooms, stairwells, mechanical and electrical systems, and telecommunications) throughout the building.

building entrance area: See **entrance room or space (telecommunications)**.

building module: The standard selected as the dimensional coordination for the design of the building, e.g., a multiple of 100 mm (4 in), since the international standards have established a 100 mm (4 in) basic module.

bundled cable: An assembly of two or more cables continuously bound together to form a single unit.

buried cable: A cable installed under the surface of the ground in such a manner that it cannot be removed without disturbing the soil.

cabinet: A container that may enclose connection devices, terminations, apparatus, wiring, and equipment.

cabinet (telecommunications): An enclosure with a hinged cover used for terminating telecommunications cables, wiring and connection devices.

cable: An assembly of one or more insulated conductors or optical fibers, within an enveloping sheath.

cable run: A length of installed media, which may include other components along its path.

cable sheath: A covering over the optical fiber or conductor assembly that may include one or more metallic members, strength members, or jackets.

cabling: A combination of all cables, jumpers, cords, and connecting hardware.

campus: The buildings and grounds having legal contiguous interconnection.

campus backbone: Cabling for interconnecting telecommunications spaces between buildings.

cavity wall: A wall built of solid masonry units arranged to provide air space within the wall.

ceiling distribution system: A distribution system that utilizes the space between a suspended or false ceiling and the structural surface above.

cell: A single raceway of a cellular or underfloor duct system.

cellular floor: A floor distribution method in which cables pass through floor cells, constructed of steel or concrete to provide a ready-made raceway for distribution of power and telecommunications cables.

cellular floor raceway: An assembly of hollow, longitudinal units constituting part of a floor, and systematically placed for the distribution of cables.

cementitious firestop: A firestopping material that is mixed with water, similar in appearance to mortar. See **firestopping**.

centralized cabling: A cabling configuration from the work area to a centralized cross-connect using pull through cables, an interconnect, or splice in the telecommunications room or telecommunications enclosure.

channel: The end-to-end transmission path between two points at which application-specific equipment is connected.

commercial building: A building or portion thereof that is intended for office use.

common equipment room (telecommunications): An enclosed space used for equipment and backbone interconnections for more than one tenant in a building or campus.

common telecommunications room: An enclosed space used for backbone interconnections for more than one tenant in a building, which may also house equipment.

computer room: An architectural space whose primary function is to accommodate data processing equipment.

concrete fill: A minimal-depth concrete pour to encase single-level underfloor duct.

conduit: (1) A raceway of circular cross-section. (2) A structure containing one or more ducts. Editorial note - For the purposes of these Standards the term conduit includes electrical metallic tubing (EMT) or electrical non-metallic tubing (ENT)

conduit system: Any combination of ducts, conduits, maintenance holes, handholes and vaults joined to form an integrated whole.

connecting hardware: A device providing mechanical cable terminations.

connector (plug), duplex; optical fiber: A remateable device that terminates two fibers and mates with a duplex receptacle.

connector, small form factor: An optical fiber duplex connector with a size approximating that of an 8-position modular outlet/connector typically used for terminating 4-pair copper cable.

consolidation point: A location for interconnection between horizontal cables extending from building pathways and horizontal cables extending into furniture pathways.

contractor: A licensed and qualified company charged with the execution of a scope of work by the Owner. Contractors include but are not limited to equipment installers/vendors, cable contractors, project managers, and all other private entities performing related work for the owner.

core area: See **building core**.

core wall: A wall that runs between structural floor and structural ceiling to separate stairwells, elevators, etc. from the rest of the building.

cord (telecommunications): A cable using stranded conductors for flexibility, as in distribution cords or line cords.

NOTE - Line cords can also use tinsel conductors.

coverage area: the area served by a device.

coverage area cable/cord: A cable or cord connecting the building automation system outlet or horizontal connection point to a building automation system device.

cross-connect: A facility enabling the termination of cable elements and their interconnection or cross-connection.

cross-connection: A connection scheme between cabling runs, subsystems, and equipment using patch cords or jumpers that attach to connecting hardware on each end.

crossover: The junction unit at the point of intersection of two cable trays, raceways, or conduit (pathways) on different planes.

customer premises: Building(s), grounds and appurtenances (belongings) under the control of the customer.

customer premises equipment: Telecommunications equipment located on the customer's premises.

delay skew: The difference in propagation delay between any two pairs within the same cable sheath.

DEMARC or demarcation point: A point where the operational control or ownership changes.

data: Electronically encoded information.

data center: a building or portion of a building whose primary function is to house a computer and its support areas.

direct-buried cable: A telecommunications cable designed to be installed under the surface of the earth, in direct contact with the soil.

distribution device: A facility located within the dwelling unit for interconnection or cross connection.

distribution device cord: A telecommunications cord that extends between the distribution device and the auxiliary disconnect outlet.

distribution duct: A raceway of rectangular cross-section placed within or just below the finished floor and used to extend the wires or cables to a specific work area.

distribution frame: A structure with terminations for connecting the cabling of a facility in such a manner that interconnection or cross-connections may be readily made.

(1) **main:** When the structure is located at the entrance facility or main cross-connect and serving the building or campus.

(2) **intermediate:** When the structure is located between the main cross-connect and the telecommunications room.

double pour: The pouring of a concrete floor in two stages.

drain wire: A non-insulated conductor placed in electrical contact with a shield.

duct: (1) A single enclosed raceway for conductors or cables. See also **conduit, raceway**. (2) A single enclosed raceway for wires or cables usually used in soil or concrete. (3) An enclosure in which air is moved. Generally part of the HVAC system of a building.

ductbank: An arrangement of ducts, for wires or cables, in tiers.

earth: See **ground**.

earthing: See **grounding**.

effectively grounded: For a definition see the NEC.

elastomeric firestop: A firestopping material resembling rubber (See also **firestopping**).

electrical closet: Floor-serving facility for housing electrical equipment, panelboards, and controls.

electrical service equipment: That portion of the electrical power installation, the service enclosure or its equivalent, up to and including the point at which the supply authority makes connection.

electromagnetic compatibility: The ability of electronic systems to operate in their intended electromagnetic environment without suffering performance degradation and without causing performance degradation in other equipment.

electromagnetic interference: Radiated or conducted electromagnetic energy that has an undesirable effect on electronic equipment or signal transmissions.

embedded duct: A duct fully enclosed inside a floor or a wall.

emergency power: A stand-alone secondary electrical supply source not dependent upon the primary electrical source.

EMI segregation: Isolation of the telecommunications signal from electromagnetic interference.

enclosure, telecommunications: A case or housing that may contain telecommunications equipment, cable terminations, or horizontal cross-connect cabling.

endpoint PSE: A power-sourcing device located in networking equipment.

end user: The owner or user of the premises cabling system.

entrance bridge: A terminal strip that is an optional component in a network interface device and is provided for the connection of ADO cable.

entrance facility (telecommunications): An entrance to a building for both public and private network service cables (including wireless) including the entrance point of the building and continuing to the entrance room or space.

entrance point (telecommunications): The point of emergence for telecommunications cabling through an exterior wall, a floor, or from a conduit.

entrance room or space (telecommunications): A space in which the joining of inter or intra building telecommunications backbone facilities takes place.
Editorial note - An entrance room may also serve as an equipment room.

equal level far-end crosstalk: A measure of the unwanted signal coupling from a transmitter at the near-end into another pair measured at the far-end, and relative to the received signal level.

equipment cable; cord: A cable or cable assembly used to connect telecommunications equipment to horizontal or backbone cabling.

Equipment distribution area: the computer room space occupied by equipment racks or cabinets.

equipment room (telecommunications): An environmentally controlled centralized space for telecommunications equipment that usually houses a main or intermediate cross-connect.

exothermic weld: A method of permanently bonding two metals together by a controlled heat reaction resulting in a molecular bond.

false ceiling: See **suspended ceiling**.

far-end crosstalk loss: A measure of the unwanted signal coupling from a transmitter at the near end into another pair measured at the far end, and relative to the transmitted signal level.

Note -- This term is also known as input/output far end crosstalk loss.

feeder duct: See **header duct**.

fiber optic: See **optical fiber**.

field wiring: An electrical connection intended to be made at the time of installation, in the field, as opposed to factory wired.

fire break: A fire-rated material, device, or assembly of parts installed along a cable, other than at a cable penetration of a fire-rated barrier, to prevent the spread of fire along a cable.

fire resistance rating: The time in hours or fraction thereof that a material or assembly of materials will withstand the passage of flame and the transmission of heat when exposed to fire under specified conditions of test and performance criteria.

fire shield: A fire-rated material, device, or assembly of parts between pathways to prevent propagation of flames from one pathway to an adjacent pathway.

firestop: A fire-rated material, device, or assembly of parts installed in a penetration of a fire-rated barrier.

firestop seals: See **Firestop system**.

firestop system: A specific construction consisting of the material(s) (firestop penetration seals) that fill the opening in the wall or floor assembly and any items that penetrate the wall or floor,

such as cables, cable trays, conduit, ducts, pipes, and any termination devices, such as electrical outlet boxes, along with their means of support.

firestopping: The process of installing listed, fire-rated materials into penetrations in fire-rated barriers to reestablish the fire-resistance rating of the barrier.

fixed devices: Any low-voltage device permanently affixed to a surface for purposes of security, fire detection or other control, data, or entertainment applications.

floor above grade: All floors above ground level.

floor serving terminal: See **terminal**.

floor slab: That part of a reinforced concrete floor which is carried on beams below.

flush duct: A duct accessible by a cover that is even with the surface it is mounted in.

furniture cluster: A contiguous group of work areas, typically including space divisions, work surfaces, storage, and seating.

Generic cabling: A structured telecommunications cabling system, capable of supporting a wide range of applications. Generic cabling can be installed without prior knowledge of the required applications. Application specific hardware is not a part of generic cabling.

ground: A conducting connection, whether intentional or accidental, between an electrical circuit (e.g., telecommunications) or equipment and the earth, or to some conducting body that serves in place of earth.

grounding: The act of creating a ground.

grounding conductor: A conductor used to connect the grounding electrode to the building's main grounding busbar.

grounding electrode: A conductor, usually a rod, pipe or plate (or group of conductors) in direct contact with the earth for the purpose of providing a low-impedance connection to the earth.

grounding electrode conductor: The conductor used to connect the grounding electrode to the equipment grounding conductor, or to the grounded conductor of the circuit at the service equipment, or at the source of a separately derived system.

grounding electrode system: For a definition use the terminology as specified in NEC, Article 250 Part H.

grounding mat: An extensive system of bare conductors, buried below the surface of the earth, intended to provide a low resistance connection to earth and to equalize the potential within the area covered.

handhole: A structure similar to a small maintenance hole in which it is expected that a person cannot enter to perform work.

hard-line trunk: A rigid coaxial cable, typically used for backbone cabling.

hard sheath cable: A cable or wire contained within a continuous inner or outer metal sheath.

header duct (trenchduct, feeder duct): A raceway of rectangular cross-section placed within the floor to tie distribution duct(s) or cell(s) to the telecommunications room.

high-order mode transient losses: Losses in power caused by the attenuation of weakly-guided high-order modes within multimode optical fiber.

home runs: A pathway or cable between two locations without a point of access in between.

horizontal cabling: 1) The cabling between and including the telecommunications outlet/connector and the horizontal cross-connect. 2) The cabling between and including the building automation system outlet or the first mechanical termination of the horizontal connection point and the horizontal cross-connect. 3) in a data center, horizontal cabling is the cabling from the horizontal cross-connect (in the main distribution area or horizontal distribution area) to the outlet in the equipment distribution area or zone distribution area.

horizontal connection point: A location for connections between horizontal cables that extend from building pathways and horizontal cables that extends to building automation systems devices and equipment.

horizontal cross-connect: A cross-connect of horizontal cabling to other cabling, e.g., horizontal, backbone, equipment.

horizontal distribution area: A space in a computer room where a horizontal cross-connect is located.

hybrid cable: An assembly of two or more cables, of the same or different types or categories, covered by one overall sheath.

hybrid optical fiber cable: An optical fiber cable containing two or more fiber types (e.g., multimode and singlemode).

identifier: An item of information that links a specific element of the telecommunications infrastructure with its corresponding record.

in floor pathway: A raceway within a floor structure.

industrial building/structure: A building or structure or portion thereof intended for uses such as transportation, manufacturing, warehousing, processing, refining, or drilling.

infrastructure (telecommunications): A collection of those telecommunications components, excluding equipment, that together provides the basic support for the distribution of all information within a building or campus.

innerduct: A nonmetallic raceway, usually circular, placed within a larger raceway.

insert: An opening into the distribution duct or cell, from which the wires or cables emerge.

insert, afterset: An insert installed after the installation of the concrete floor slab or other flooring material.

insert, preset: An insert installed prior to the installation of the concrete floor slab or other flooring material.

insertion loss: The signal loss resulting from the insertion of a component, or link, or channel, between a transmitter and receiver (often referred to as attenuation).

insertion loss deviation: The difference between the actual insertion loss as measured on a permanent link or channel and the insertion loss as determined by adding the component losses.

insulation displacement connection: An electrical connection made by inserting an insulated wire into a metallic slot.

insulation displacement contact: See insulation displacement termination.

insulation displacement connection, accessible: An ID connection in which it is possible to access test points for carrying out mechanical tests and electrical measurements without deactivation of any design feature intended to establish or maintain the insulation displacement connection.

insulation displacement connection, non-accessible: An ID connection in which it is not possible to access test points for carrying out mechanical tests and electrical measurements without deactivation of any design feature.

insulation displacement termination: A contact suitable for making an electrical connection with an insulated conductor.

insulation piercing connection: An electrical connection made by piercing an insulated wire with a metallic element.

insulation piercing contact: An electrical connection made by piercing an insulated wire with a metallic element.

interconnection: A connection scheme that employs connecting hardware for the direct connection of a cable to another cable without a patch cord or jumper.

interconnecting bonding conductor: A conductor that interconnects the telecommunications bonding backbones.

intermediate cross-connect: A cross-connect between first level and second level backbone cabling.

intermediate distribution frame: See **distribution frame**.

intra-building telecommunications backbone: This term is out dated. See building backbone.

intumescent firestop: A firestopping material that expands under the influence of heat.

jack contact: The current carrying metallic member in a modular jack.

jack header: A raceway similar to a header duct, usually provided in short lengths to connect a quantity of distribution ducts together.

jumper: 1) An assembly of twisted-pairs without connectors, used to join telecommunications circuits/links at the cross-connect. 2) A length of optical fiber cable with a connector plug on each end.

junction box: A location in the pathway system that allows transition of pathways and access to cables.

keying: The mechanical feature of a connector system that guarantees correct orientation of a connection, or prevents the connection to a jack, or to an optical fiber adapter of the same type intended for another purpose.

light commercial building: A building or portion thereof that is intended for use with one to four non-residential exchange access lines per tenant.

link: A transmission path between two points, not including terminal equipment, work area cables, and equipment cables.

linkage: A connection between a record and an identifier or between records.

listed: Equipment included in a list published by an organization, acceptable to the authority having jurisdiction, that maintains periodic inspection of production of listed equipment, and whose listing states either that the equipment or material meets appropriate standards or has been tested and found suitable for use in a specified manner.

local exchange carrier: The telecommunications company that provides public switched network access service.

longitudinal conversion loss: A ratio, expressed in dB, of measured differential voltage relative to the common mode voltage on the same conductor pair applied at the same end.

longitudinal conversion transfer loss: A ratio, expressed in dB, of measured differential voltage at one end of a conductor pair relative to the common mode voltage applied on any pair at the opposite end or on any other pair on the same end.

main cross-connect: A cross-connect for first level backbone cables, entrance cables, and equipment cables.

main distribution area: The space in a computer room where the main cross-connect is located.

main distribution frame: See **distribution frame**.

main terminal room: See main terminal space.

main terminal space: The location of the cross-connect point of incoming cables from the telecommunications external network and the premises cable system (See also common equipment room).

maintenance hole (telecommunications): A vault located in the ground or earth as part of an underground duct system and used to facilitate placing, connectorization, and maintenance of cables as well as the placing of associated equipment, in which it is expected that a person will enter to perform work.

mechanical room: An enclosed space serving the needs of mechanical building systems.

media (telecommunications): Wire, cable, or conductors used for telecommunications.

membrane penetration: An opening through only one surface or side of a barrier.

midspan PSE: A power-sourcing device located in a component within a channel.

minimum point of entry: Either the closest practicable point to where the carrier facilities cross the property line or the closest practicable point to where the cabling enters a multi-unit building or buildings.

mode: A path of light in an optical fiber.

modular jack: A female telecommunications connector that may be keyed or unkeyed and may have 6 or 8 contact positions, but not all the positions need be equipped with jack contacts.

modular plug: A male telecommunications connector for cable or cords that may be keyed or unkeyed and may have 6 or 8 contact positions, but not all the positions need be equipped with contacts.

modular plug cord: A length of cable with a modular plug on both ends.

monolithic pour: The single, continuous pouring of a concrete floor or columns of any given floor of a building structure.

monolithic slab: The result of a monolithic pour.

multimedia: (1) An application that communicates to more than one of the human sensory receptors. (2) Applications that communicate information by more than one means.

multimode optical fiber: An optical fiber that carries many paths of light.

multipair cable: A cable having more than four pairs.

multipoint bus: An open sequence of connected devices.

multipoint ring: A closed sequence of connected devices.

multi-user telecommunications outlet assembly: A grouping in one location of several telecommunications outlet/connectors.

network interface device: The point of connection between networks.

network termination equipment: See **network interface device**.

open office: A floor space division provided by furniture, moveable partitions, or other means instead of by building walls.

optical fiber: Any filament made of dielectric materials that guide light.

optical fiber cable: An assembly consisting of one or more optical fibers.

optical fiber duplex connection: A mated assembly of two duplex connectors and a duplex adapter.

outlet (telecommunications): A designated location containing one or more telecommunications outlet/connectors.

outlet/connector (telecommunications): A connecting device in the work area or living space on which horizontal cable or outlet cable terminates.

outlet box (telecommunications): A housing used to hold telecommunications outlet/connectors.

outlet cable: A cable placed in a residential unit extending directly between the telecommunications outlet/connector and the distribution device.

outlet/connector (telecommunications): A connecting device in the work area on which horizontal cable or outlet cable terminates.

outlet/connector (building automation system): A connecting device between a horizontal cable and coverage area cable/cord.

outside plant: Telecommunications infrastructure designed for installation exterior to buildings.

passive cross-connect: A facility enabling the termination of cable elements and their interconnection or cross-connection by means of jumpers or patchcords.

patch cord: A length of cable with a plug on one or both ends.

patch panel: A connecting hardware system that facilitates cable termination and cabling administration using patch cords.

pathway: A facility for the placement of telecommunications cable.

penetration: An opening in a fire-rated barrier.

penetration seals: See **firestop system**.

permanent link: A test configuration for a link excluding test cords and patch cords.

position bonding terminal: A device located in the work area that electrically bonds cabling or cabling and equipment to ground.

pigtail: one or more conductors or fibers with only one end terminated.

plaster ring: A metal or plastic plate that attaches to wallboard or a wall stud for the purpose of mounting a telecommunications faceplate.

plenum: A closed compartment or chamber to which one or more air ducts are connected and that forms part of the air distribution system. May also be referred to as a return-air system.

poke-thru device: An assembly that allows through-penetration of floor decking with telecommunication cables, or power, or both, while maintaining the fire-rating integrity of the floor.

poke-thru system: A poke-thru device installed in a penetration through a fire-resistant floor structure.

post-tensioned concrete: A type of reinforced concrete construction in which the embedded steel members are first put under tension, the concrete poured and allowed to harden, and the tension of the steel members released causing compression of the concrete.

power sum attenuation-to-crosstalk ratio: A ratio in dB, determined by subtracting the insertion loss from the power sum near-end crosstalk loss.

power sum equal level far-end crosstalk: A computation of the unwanted signal coupling from multiple transmitters at the near-end into a pair measured at the far-end, and normalized to the received signal level.

power sum near-end crosstalk loss: A computation of the unwanted signal coupling from multiple transmitters at the near-end into a pair measured at the near-end.

prewiring: (1) Wiring installed before walls are enclosed or finished. (2) Wiring installed in anticipation of future use or need.

private branch exchange: A private telecommunications switching system.

propagation delay: The time required for a signal to travel from one end of the transmission path to the other end.

pull box: A housing located in a pathway run used to facilitate the placing of wire or cables.

pullcord; pullwire: A cord or wire placed within a raceway and used to pull wire and cable through the raceway.

pull strength: See **pull tension**.

pull tension: The pulling force that can be applied to a cable.

raceway: Any enclosed channel designed for holding wires or cables.

radio frequency interference: Electromagnetic interference within the frequency band for radio transmission.

rearrangement: An action taken to replace, add, adapt or remove existing premises wiring system components.

record: A collection of detailed information related to a specific element of the telecommunications infrastructure.

record drawing (as-built): A plan, on paper, that graphically documents and illustrates the installed telecommunications infrastructure in a building, or portion thereof.

reinforced concrete: A type of construction in which steel (reinforcement) and concrete are combined, with the steel-resisting tension and the concrete-resisting compression.

report: A presentation of a collection of information from the various records.

resident: The individual responsible and accountable for the telecommunications services provided to the premises that may reside on the premises or, in the case of a rental unit, be the owner or property manager.

residential gateway: A device that enables communication among networks in the residence and between residential networks and service providers' networks.

return loss: A ratio expressed in dB of the power of the outgoing signal to the power of the reflected signal.

saddle: A device for establishing the position of the raceway or raceways within the concrete relative to the screed line, and for maintaining the spacing between the raceways.

screed line: The line to which poured concrete is leveled.

screen: An element of a cable formed by a shield.

screened twisted-pair (ScTP): A balanced cable with an overall screen.

service entrance: See **entrance facility (telecommunications)**.

service equipment (power): The necessary equipment, usually consisting of a circuit breaker or switch and fuses, and their accessories, located near the point of entrance of supply conductors to a building or other structure, or an otherwise defined area, and intended to constitute the main control and means of cutoff of the electrical supply.

service fitting: An outlet box to house the connections for telecommunications at the user work area. See also **insert**.

service provider: The operator of any service that furnishes telecommunications content (transmissions) delivered over access provider facilities.

sheath: See **cable sheath**.

shield: A metallic layer placed around a conductor or group of conductors.

shielded enclosure cabinet: A metal electronics cabinet, constructed with welded seams and conductive gaskets on the doors that serve as an effective shield against electromagnetic radiation.

singlemode optical fiber: An optical fiber that carries only one path of light.

slab on grade: Concrete floor placed directly on soil, without basement or crawlspace.

sleeve: An opening, usually circular, through the wall, ceiling, or floor to allow the passage of cables.

slip sleeve: An oversized conduit that moves easily along an inner conduit and covers a gap or missing part of the smaller conduit.

slot: An opening through a wall, floor, or ceiling, usually rectangular, to allow the passage of cables.

small form factor connector: See **connector, small form factor**.

space (telecommunications): An area used for housing the installation and termination of telecommunications equipment and cable, e.g., common equipment rooms, equipment rooms, common telecommunications rooms, telecommunications rooms, telecommunications enclosures, work areas, and maintenance holes/handholes.

splice: A joining of conductors, meant to be permanent.

splice box: An enclosed space between pathways intended to house a cable splice.

splice closure: A device used to protect a splice.

star topology: A topology in which telecommunications cables are distributed from a central point.

station conductor: A wire that terminates at the equipment side of the protector.

support strand (messenger): A strength element used to carry the weight of the telecommunications cable.

suspended ceiling: A ceiling that creates an area or space between the ceiling material and the structure above.

telecommunications: Any transmission, emission, and reception of signs, signals, writings, images, and sounds, that is, information of any nature by cable, radio, optical, or other electromagnetic systems.

telecommunications bonding backbone: A conductor that interconnects the telecommunications main grounding busbar (TMGB) to the telecommunications grounding busbar (TGB).

telecommunications closet: See telecommunications room

telecommunications enclosure: See enclosure, telecommunications

telecommunications entrance facility: See **entrance facility (telecommunications)**.

telecommunications entrance point: See **entrance point (telecommunications)**.

telecommunications entrance room or space: See **entrance room or space (telecommunications)**.

telecommunications equipment room: See **equipment room (telecommunications)**.

telecommunications grounding busbar: A common point of connection for telecommunications system and equipment bonding to ground, and located in the telecommunications room or equipment room.

telecommunications infrastructure: See **infrastructure (telecommunications)**.

telecommunications main grounding busbar: A busbar placed in a convenient and accessible location and bonded, by means of the bonding conductor for telecommunications, to the buildings service equipment (power) ground.

telecommunications media: See **media (telecommunications)**.

telecommunications outlet: See **outlet/connector (telecommunications)**.

telecommunications room: An enclosed architectural space designed to contain telecommunications equipment, cable terminations, or cross-connect cabling.

telecommunications service entrance: See **entrance facility (telecommunications)**.

telecommunications space: See **space (telecommunications)**.

terminal: (1) a point at which information may enter or leave a communications network. (2) The input-output associated equipment. (3) A device by means of which wires may be connected to each other.

termination: This term is outmoded. See **connecting hardware**.

termination hardware: This term is outmoded. See **connecting hardware**.

termination position: A discrete element of connecting hardware where telecommunications conductors are terminated.

through penetration: A continuous opening that passes through both surfaces of a fire-rated barrier.

topology: The physical or logical arrangement of a telecommunications system.

transfer impedance: A measure of shielding performance determined by the ratio of the voltage on the conductors enclosed by a shield to the surface currents on the outside of the shield.

transition point: A location in the horizontal cabling where flat undercarpet cable connects to round cable.

transverse conversion loss: A ratio, expressed in dB, of the measured common mode voltage on a pair relative to the differential mode voltage on the same pair applied at the same end.

trenchduct: See **header duct**.

trough: A pathway for the containment of cable, typically provided with a removable cover.

two-level duct: An underfloor raceway system installed with the header raceways and the distribution raceways on two different planes.

underground cable: A telecommunications cable designed to be installed under the surface of the earth in a trough or duct that isolates the cable from direct contact with the soil.

underfloor raceway: A pathway placed within the floor and from which wires and cables emerge to a specific floor area.

uninterruptible power supply: A buffer between utility power or other power source and a load that requires continuous precise power.

usable floor space: Floor space which is capable of being used as a work area.

User code: A unique designation assigned to a person who is expected to use the circuit, equipment, service etc. serving a particular work area (e.g.: telephone number, a name, a circuit number, telecommunications outlet/connector, or a logical address).

Utility column: An enclosed pathway extending from the ceiling to furniture or to the floor that forms a pathway for electrical wiring, telecommunications cable, or both.

Utility tunnel: An enclosed passageway usually placed between buildings, for the distribution of utility services.

vendor: See **contractor**

wire: An individually insulated solid or stranded metallic conductor.

wireless: The use of radiated electromagnetic energy (e.g., radio frequency and microwave signals, light) traveling through space to convey information.

wire run: See **cable run**.

work area: A building space where the occupants interact with telecommunications terminal equipment.

work area cable (cord): A cable connecting the telecommunications outlet/connector to the terminal equipment.

zone box: An enclosure used to house one or more of the following; a) a consolidation point, b) a horizontal connection point, c) building automation system outlets.

Zone distribution area: the space in the data center where the zone outlet is located.

Zone distribution area: a space in a computer room where a zone outlet or a consolidation point is located.

Zone outlet: a connecting device in the zone distribution area terminating the horizontal cable enabling equipment cable connections to the equipment distribution area.